

PREFACE

In a bid to standardize higher education in the country, the University Grants Commission (UGC) has introduced Choice Based Credit System (CBCS) based on five types of courses viz. *core, discipline specific, generic elective, ability and skill enhancement* for graduate students of all programmes at Honours level. This brings in the semester pattern, which finds efficacy in sync with credit system, credit transfer, comprehensive continuous assessments and a graded pattern of evaluation. The objective is to offer learners ample flexibility to choose from a wide gamut of courses, as also to provide them lateral mobility between various educational institutions in the country where they can carry their acquired credits. I am happy to note that the University has been recently accredited by National Assessment and Accreditation Council of India (NAAC) with grade “A”.

UGC (Open and Distance Learning Programmes and Online Programmes) Regulations, 2020 have mandated compliance with CBCS for U. G. programmes for all the HEIs in this mode. Welcoming this paradigm shift in higher education, Netaji Subhas Open University (NSOU) has resolved to adopt CBCS from the academic session 2021-22 at the Under Graduate Degree Programme level. The present syllabus, framed in the spirit of syllabi recommended by UGC, lays due stress on all aspects envisaged in the curricular framework of the apex body on higher education. It will be imparted to learners over the six semesters of the Programme.

Self Learning Materials (SLMs) are the mainstay of Student Support Services (SSS) of an Open University. From a logistic point of view, NSOU has embarked upon CBCS presently with SLMs in English/Bengali. Eventually, the English version SLMs will be translated into Bengali too, for the benefit of learners. As always, all of our teaching faculties contributed in this process. In addition to this we have also requisitioned the services of best academics in each domain in preparation of the new SLMs. I am sure they will be of commendable academic support. We look forward to proactive feedback from all stakeholders who will participate in the teaching-learning based on these study materials. It has been a very challenging task well executed by the teachers, officers & staff of the University and I heartily congratulate all concerned in the preparation of these SLMs.

I wish you all a grand success.

Professor (Dr.) Ranjan Chakraborti
Vice-Chancellor



Netaji Subhas Open University
Under Graduate Degree Programme
Choice Based Credit System (CBCS)
Subject : Honours in Physics (HPH)
Course : Renewable Energy and Energy Harvesting
Course Code : SE-PH-21

First Print : November, 2022

Printed in accordance with the regulations of the Distance
Education Bureau of the University Grants Commission.



Netaji Subhas Open University
Under Graduate Degree Programme
Choice Based Credit System (CBCS)
Subject : Honours in Physics (HPH)
Course : Renewable Energy and Energy Harvesting
Course Code : SE-PH-21

: Board of Studies :

Members

Professor Kajal De
(Chairperson)
Director, School of Sciences, NSOU

Dr. Gahul Amin
Associate Professor of Physics
Netaji Subhas Open University

Dr. Gautam Mallik
Associate Professor of Physics
Netaji Subhas Open University

Mr. Pranab Nath Mallik
Associate Professor of Physics
Netaji Subhas Open University

Dr. Gautam Gangopadhyay
Professor of Physics
University of Calcutta

Dr. Rupayan Bhattacharya
Retd. Principal
Gurudas College

Dr. Amit Kumar Chakraborty
Associate Professor of Physics
National Institute of Technology

Dr. Subhratanu Bhattacharya
Assistant Professor of Physics
Kalyani University

Dr. Manik Sanyal
Associate Professor of Physics
Barasat College

: Course Writer :

Dr. Gahul Amin
Associate Professor of Physics
Netaji Subhas Open University

: Course Editor :

Dr. Malay Kumar Ghosh
Associate Professor of Physics
S.R. Fatepuria College, Beldanga

: Format Editor :

Dr. Gahul Amin
Netaji Subhas Open University

Notification

All rights reserved. No part of this Self-Learning Material (SLM) may be reproduced in any form without permission in writing from Netaji Subhas Open University.

Dr. Ashit Baran Aich
Registrar (Acting)



**NETAJI SUBHAS
OPEN UNIVERSITY**

**UG : Physics
(HPH)**

**Course : Renewable Energy and Energy Harvesting
Course Code : SE-PH-21**

Unit 1	□ Fossil fuels and alternative sources of energy	7-15
Unit 2	□ Solar Energy	16-32
Unit 3	□ Wing Energy Harvesting	33-43
Unit 4	□ Ocean Energy	44-53
Unit 5	□ Geothermal Energy	54-58
Unit 6	□ Hydro Energy	59-62
Unit 7	□ Piezoelectric Energy harvesting	63-77
Unit 8	□ Electromagnetic Energy Harvesting	78-84
	Reference	85

Unit 1 Fossil fuels and alternative sources of energy

Contents

- 1.1 Objective**
- 1.2 Introduction**
- 1.3 Fossil fuels and nuclear energy**
- 1.4 Non-conventional energy sources**
- 1.5 Summary**
- 1.6 Questions**

1.1 Objective

By learning this unit you will gather knowledge about different kind energy sources and their uses in different sectors. It will help you to understand the limitation of conventional sources of energy and possible switch of energy sources

1.2 Introduction

We, in our daily lives, use energy from various sources for doing work. We use diesel to run our trains. We use electricity to light our street-lamps. Or we use energy in our muscles to cycle to school. The muscular energy for carrying out physical work, electrical energy for running various appliances, chemical energy for cooking food or running a vehicle all come from some source. We will discuss all the source of energy available at present on the surface of earth.

1.3 Fossil fuels and nuclear energy

In ancient times, wood was the most common source of heat energy. The energy of flowing water and wind was also used for limited activities. Can you think of some of these uses? The exploitation of coal as a source of energy made the industrial revolution possible. Increasing industrialisation has led to a better quality of life all over the world. It has also caused the global demand for energy to grow at a tremendous rate. The growing demand for energy was largely met by the fossil fuels - coal and petroleum. Our technologies were also developed for using these energy sources. But these fuels were formed over millions of years ago and there are only limited reserves. The fossil fuels are non-renewable sources of energy, so we need to conserve them. If we were to continue consuming these

sources at such alarming rates, we would soon run out of energy! In order to avoid this, alternate sources of energy were explored. But we continue to be largely dependent on fossil fuels for most of our energy requirements.

Burning fossil fuels has other disadvantages too. We learnt in about the air pollution caused by burning of coal or petroleum products. The oxides of carbon, nitrogen and sulphur that are released on burning fossil fuels are acidic oxides. These lead to acid rain which affects our water and soil resources. In addition to the problem of air pollution, recall the green-house effect of gases like carbon dioxide.

The pollution caused by burning fossil fuels can be somewhat reduced by increasing the efficiency of the combustion process and using various techniques to reduce the escape of harmful gases and ashes into the surroundings. Besides being used directly for various purposes-in gas stoves and vehicles, do you know fossil fuels are the major fuels used for generating electricity? Let us produce some electricity at our own small plant in the class and see what goes into producing our favourite form of energy.

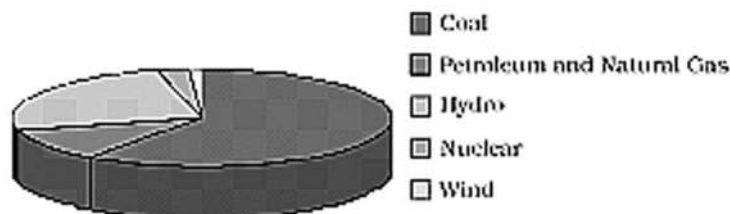

Nuclear Energy :

How is nuclear energy generated? In a process called nuclear fission, the nucleus of a heavy atom (such as uranium, plutonium or thorium), when bombarded with low-energy neutrons, can be split apart into lighter nuclei. When this is done, a tremendous amount of energy is released if the mass of the original nucleus is just a little more than the sum of the masses of the individual products. The fission of an atom of uranium, for example, produces 10 million times the energy produced by the combustion of an atom of carbon from coal. In a nuclear reactor designed for electric power generation, such nuclear 'fuel' can be part of a self-sustaining fission chain reaction that releases energy at a controlled rate. The released energy can be used to produce steam and further generate electricity.

In a nuclear fission, the difference in mass, Δm , between the original nucleus and the product nuclei gets converted to energy E at a rate governed by the famous equation,

$$E = \Delta mc^2,$$

The major hazard of nuclear power generation is the storage and disposal of spent or used fuels - the uranium still decaying into harmful subatomic particles (radiations). Improper nuclear-waste storage and disposal result in environmental contamination. Further, there is a risk of accidental leakage of nuclear radiation. The high cost of installation of a nuclear power plant, high risk of environmental contamination and limited availability of uranium makes large-scale use of nuclear energy prohibitive.

Nuclear energy was first used for destructive purposes before nuclear power stations were designed. The fundamental physics of the fission chain reaction in a nuclear weapon is similar to the physics of a controlled nuclear reactor, but the two types of device are engineered quite differently.

Nuclear fusion

Currently all commercial nuclear reactors are based on nuclear fission. But there is another possibility of nuclear energy generation by a safer process called nuclear fusion. Fusion means joining lighter nuclei to make a heavier nucleus, most commonly hydrogen or hydrogen isotopes to create helium, such as

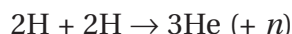

It releases a tremendous amount of energy, according to the Einstein equation, as the mass of the product is little less than the sum of the masses of the original individual nuclei.

Such nuclear fusion reactions are the source of energy in the Sun and other stars. It takes considerable energy to force the nuclei to fuse. The conditions needed for this process are extreme-millions of degrees of temperature and millions of pascals of pressure.

The hydrogen bomb is based on thermonuclear fusion reaction. A nuclear bomb based on the fission of uranium or plutonium is placed at the core of the hydrogen bomb. This nuclear bomb is embedded in a substance which contains deuterium and lithium. When the nuclear bomb (based on fission) is detonated, the temperature of this substance is raised to 10⁷ K in a few microseconds. The high temperature generates sufficient energy for the light nuclei to fuse and a devastating amount of energy is released.

Limitation of conventional energy :

The fast and foremost limitation of this kind of energy sources is its quantity which is fixed in the earth crust and it is reducing by our abnormal uses and will end up in near future. So we need to think some non conventional sources which is available always like sunlight, wind, geothermal energy etc.

1.4 Non-conventional energy sources

With technological progress, our demand for energy increases day by day. Our life-styles are also changing, we use machines to do more and more of our tasks.

As our demand for energy increases, we need to look for more and more sources of energy. We could develop the technology to use the available or known sources of energy more efficiently and also look to new sources of energy. Any new source of energy we seek to exploit would need specific devices developed with that source in mind. We shall now look at some of the latest sources of energy that we seek to tap, and the technology designed to capture and store energy from that source.

Wind Energy :

We saw in Class IX how unequal heating of the landmass and water bodies by solar radiation generates air movement and causes winds to blow. This kinetic energy of the wind can be used to do work. This energy was harnessed by windmills in the past to do mechanical work.

For example, in a water-lifting pump, the rotatory motion of windmill is utilised to lift water from a well. Today, wind energy is also used to generate electricity. A windmill essentially consists of a structure similar to a large electric fan that is erected at some height on a rigid support (Fig. 1.4.1).

To generate electricity, the rotatory motion of the windmill is used to turn the turbine of the electric generator. The output of a single windmill is quite small and cannot be used for commercial purposes. Therefore, a number of windmills are erected over a large area, which is known as wind energy farm. The energy output of each windmill in a farm is coupled together to get electricity on a commercial scale.



Fig.1.4.1 : A windmill

Wind energy is an environment-friendly and efficient source of renewable energy. It requires no recurring expenses for the production of electricity. But there are many limitations in harnessing wind energy. Firstly, wind energy farms can be established only at those places where wind blows for the greater part of a year. The wind speed should also be higher than 15 km/h to maintain the required speed of the turbine. Furthermore, there should be some back-up facilities (like storage cells) to take care of the energy needs during a period when there is no wind. Establishment of wind energy farms requires large area of land. For a 1 MW generator, the farm needs about 2 hectares of land. The initial cost of establishment of the farm is quite high. Moreover, since the tower and blades are exposed to the vagaries of nature like rain, Sun, storm and cyclone, they need a high level of maintenance.

Tidal Energy :

Due to the gravitational pull of mainly the moon on the spinning earth, the level of water in the sea rises and falls. If you live near the sea or ever travel to some place near the sea, try and observe how the sea-level changes during the day. This phenomenon is called high and low tides and the difference in sea-levels gives us tidal energy. Tidal energy is harnessed by constructing a dam across a narrow opening to the sea. A turbine fixed at the opening of the dam converts tidal energy to electricity. As you can guess, the locations where such dams can be built are limited.

Wave energy systems :

Similarly, the kinetic energy possessed by huge waves near the seashore can be trapped in a similar manner to generate electricity. The waves are generated by strong winds blowing across the sea. Wave energy would be a viable proposition only where waves are very strong. A wide variety of devices have been developed to trap wave energy for rotation of turbine and production of electricity.

Ocean Thermal Energy Conversion :

The water at the surface of the sea or ocean is heated by the Sun while the water in deeper sections is relatively cold. This difference in temperature is exploited to obtain energy in ocean-thermal-energy conversion plants. These plants can operate if the temperature difference between the water at the surface and water at depths up to 2 km is 20 K (20°C) or more. The warm surface-water is used to boil a volatile liquid like ammonia. The vapours of the liquid are then used to run the turbine of generator. The cold water from the depth of the ocean is pumped up and condense vapour again to liquid.

The energy potential from the sea (tidal energy, wave energy and ocean thermal energy) is quite large, but efficient commercial exploitation is difficult.

Solar Energy :

The Sun has been radiating an enormous amount of energy at the present rate for nearly 5 billion years and will continue radiating at that rate for about 5 billion years more. Only a small part of solar energy reaches the outer layer of the earth's atmosphere. Nearly half of it is absorbed while passing through the atmosphere and the rest reaches the earth's surface.

A black surface absorbs more heat as compared to a white or a reflecting surface under identical conditions. Solar cookers (Fig. 14.6) and solar water heaters use this property in their working. Some solar cookers achieve a higher temperature by using mirrors to focus the rays of the Sun. Solar cookers are covered with a glass plate. Recall what we have learnt about the green-house effect. Does this explain why a glass plate is used?

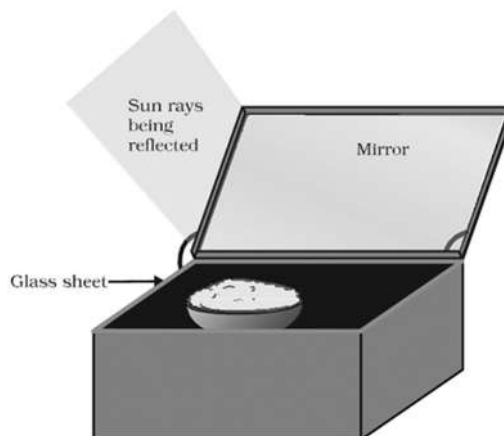

Fig. 1.4.2 : A Solar Cooker

It is easy to see that these devices are useful only at certain times during the day. This limitation of using solar energy is overcome by using solar cells that convert solar energy into electricity. A typical cell develops a voltage of 0.5-1 V and can produce about 0.7 W of electricity when exposed to the Sun. A large number of solar cells are, combined in an arrangement called solar cell panel that can deliver enough electricity for practical use.

The principal advantages associated with solar cells are that they have no moving parts, require little maintenance and work quite satisfactorily without the use of any focussing device. Another advantage is that they can be set up in remote and inaccessible hamlets or very sparsely inhabited areas in which laying of a power transmission line may be expensive and not commercially viable.

Silicon, which is used for making solar cells, is abundant in nature but availability of the special grade silicon for making solar cells is limited. The entire process of manufacture is still very expensive, silver used for interconnection of the cells in the panel further adds to the cost. In spite of the high cost and low efficiency, solar cells are used for many scientific and technological applications. Artificial satellites and space probes like Mars orbiters use solar cells as the main source of energy. Radio or wireless transmission systems or TV relay stations in remote locations use solar cell panels. Traffic signals, calculators and many toys are fitted with solar cells. The solar cell panels are mounted on specially designed inclined

roof tops so that more solar energy is incident over it. The domestic use of solar cells is, however, limited due to its high cost.

Bio-Mass, Biochemical conversion and Biogas generation :

We mentioned earlier that wood has been used as a fuel for a long time. If we can ensure that enough trees are planted, a continuous supply of fire-wood can be assured. You must also be familiar with the use of cow-dung cakes as a fuel. Given the large live-stock population in India, this can also assure us a steady source of fuel. Since these fuels are plant and animal products, the source of these fuels is said to be bio-mass. These fuels, however, do not produce much heat on burning and a lot of smoke is given out when they are burnt. Therefore, technological inputs to improve the efficiency of these fuels are necessary. When wood is burnt in a limited supply of oxygen, water and volatile materials present in it get removed and charcoal is left behind as the residue. Charcoal burns without flames, is comparatively smokeless and has a higher heat generation efficiency.

Similarly, cow-dung, various plant materials like the residue after harvesting the crops, vegetable waste and sewage are decomposed in the absence of oxygen to give bio-gas. Since the starting material is mainly cow-dung, it is popularly known as 'gobar-gas'. Bio-gas is produced in a plant as shown in Fig. 1.4.3

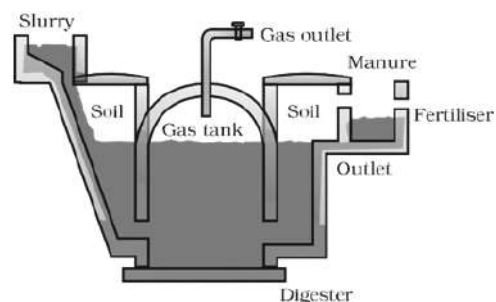

Fig 1.4.3 Schematic Diagram of a Bio Gas Plant

The plant has a dome-like structure built with bricks. A slurry of cow-dung and water is made in the mixing tank from where it is fed into the digester. The digester is a sealed chamber in which there is no oxygen. Anaerobic micro-organisms that do not require oxygen decompose or break down complex compounds of the cow-dung slurry. It takes a few days for the decomposition process to be complete and generate gases like methane, carbon dioxide, hydrogen and hydrogen sulphide. The bio-gas is stored in the gas tank above the digester from which they are drawn through pipes for use.

Bio-gas is an excellent fuel as it contains up to 75% methane. It burns without smoke, leaves no residue like ash in wood, charcoal and coal burning. Its heating capacity is high. Bio-gas is also used for lighting. The slurry left behind is removed periodically and used as excellent manure, rich in nitrogen and phosphorous. The large-scale utilisation of bio-waste and sewage material provides a safe and efficient method of waste-disposal besides supplying energy and manure. Do you think that bio-mass is a renewable source of energy?

Geothermal energy :

Due to geological changes, molten rocks formed in the deeper hot regions of earth's crust are pushed upward and trapped in certain regions called 'hot spots'. When underground water comes in contact with the hot spot, steam is generated. Sometimes hot water from that region finds outlets at the surface. Such outlets are known as hot springs. The steam trapped in rocks is routed through a pipe to a turbine and used to generate electricity. The cost of production would not be much, but there are very few commercially viable sites where such energy can be exploited. There are number of power plants based on geothermal energy operational in New Zealand and United States of America.

Ocean Thermal Energy :

The water at the surface of the sea or ocean is heated by the Sun while the water in deeper sections is relatively cold. This difference in temperature is exploited to obtain energy in ocean-thermal-energy conversion plants. These plants can operate if the temperature difference between the water at the surface and water at depths up to 2 km is 20 K (20°C) or more. The warm surface-water is used to boil a volatile liquid like ammonia. The vapours of the liquid are then used to run the turbine of generator. The cold water from the depth of the ocean is pumped up and condense vapour again to liquid.

The energy potential from the sea (tidal energy, wave energy and ocean thermal energy) is quite large, but efficient commercial exploitation is difficult.

Hydroelectricity :

Another traditional source of energy was the kinetic energy of flowing water or the potential energy of water at a height. Hydro power plants convert the potential energy of falling water into electricity. Since there are very few water-falls which could be used as a source of potential energy, hydro power plants are associated with dams. In the last century, a large number of dams were built all over the world.

In order to produce hydel electricity, high-rise dams are constructed on the river to obstruct the flow of water and thereby collect water in larger reservoirs. The water level rises and in this process the kinetic energy of flowing water gets transformed into potential energy. The water from the high level in the dam is carried through pipes, to the turbine, at the bottom of the dam. Since the water in the reservoir would be refilled each time it rains (hydro power is a renewable source of energy) we would not have to worry about hydro electricity sources getting used up the way fossil fuels would get finished one day.

But, constructions of big dams have certain problems associated with it. The dams can be constructed only in a limited number of places, preferably in hilly terrains. Large areas of agricultural land and human habitation are to be sacrificed as they get submerged. Large eco-systems are destroyed when submerged under the water in dams. The vegetation which is submerged rots under anaerobic conditions and gives rise to large amounts of methane which is also a greenhouse gas. It creates the problem of satisfactory rehabilitation of displaced people. Opposition to the construction of Tehri Dam on the river Ganga and Sardar Sarovar project on the river Narmada are due to such problems.

1.5 Summary

There are ample source of non fossil fuel energy in the earth. Using water, air, sunlight, geo thermal energy we harvest to save the mankind. Nowadays different approach are being taken to harvest such a huge source of energy.

1.6 Questions

1. What is solar energy? How it can be used in a sustainable way?
2. What is non conventional sources of energy? Why it is better than conventional source of energy?
3. What is geo thermal energy?
4. What is tidal energy? where it can be built to use this energy?
5. What is the problem of use of conventional source of energy and what is the environmental impact?

Unit 2 Solar Energy

Contents

- 2.1 Objective**
- 2.2 Introduction**
- 2.3 Solar energy, its importance**
- 2.4 Different method of use of Solar energy**
- 2.5 Solar cell and its application**
- 2.6 Summary**
- 2.7 Questions**

2.1 Objective

By going through this unit, you will gather knowledge about solar energy and different kind of methods use to tap the solar energy. It will help you to understand the importance of solar energy and it is one of the major non-conventional sources of energy which we can use throughout the year.

2.2 Introduction

The fossil fuels presently meet all global energy needs to some extent. These Fossil Fuels should be slowly replaced by renewable energy sources in the view of their depletion rates and emission legislation. The usage of renewable energy sources can reduce the pollutant emissions into the atmosphere. Especially the exploration of solar energy can play vital role in developed and developing countries. Solar energy is defined as the sun's radiation that reaches the earth. It is the most readily available source of energy.

The sun is the earth's power station and the source of all energy on our planet. The ways capturing of the solar energy for many applications have become an important research area in recent days. In developing countries like India where the energy problems is very serious, in spite of discoveries of oil and gas off the west coast, the important of crude oil continuous to increase and the price paid for all other expenditure. India being leader in wind power generation in the sector of solar energy few more developments is needed. One of them are 35000 km² area of Thar Desert has been set aside for solar power projects, sufficient to generate 700 GW to 21000 GW.

Solar energy is widely utilized in the form of Solar Lamps, Solar Water heater, Solar Cooker and solar pumps and solar energy is used for heat buildings and to provide low temperature heat for Industry and Agriculture is a well-known technology. India has large area in the form of a deserts, lakes, and rivers for installation of solar plants. The amount of solar energy produced in India 2007 was less than 1% of total energy demand. The grid interactive solar powers as of December 2010 were 10 MW.

Solar energy is widely used in India. Solar energy is a exhaustible source of renewable energy. It is used in the form of solar water pumps, solar lamps, solar water heaters and cooking purpose. Solar energy can be tapped directly (e.g., PV); indirectly as with wind, biomass, and hydropower; or as fossil biomass fuels such as coal, natural gas, and oil. Sunlight is by far the largest carbon-free energy source on the planet. More energy from sunlight strikes the Earth in 1 hour (4.3×10^{20} J) than all the energy consumed on the planet in a year (4.1×10^{20} J).

Although the Earth receives about 10 times as much energy from sunlight each year as that contained in all the known reserves of coal, oil, natural gas, and uranium combined, renewable energy has been given a dismally low priority by most political and business leaders. Even now a days, unelectrified villages are in India. These villages developed by using solar energy. With about 300 clear sunny days in a year, India's theoretical solar power reception, on only its land area. The daily average solar energy incident over India varies 4 to 7 kWh/m², which is more than current total energy consumption.

However, India is ranked number one in terms of solar energy production per watt installed. The state has commissioned Asia's biggest solar park at Chakra Village. The park is has generating capacity of 214 MW out of planned capacity of 500 MW. The state also has proposal for generation of power using solar panels on the Narmada canal branches. Rajasthan the India's sunniest state is next of Gujarat with proposals for many solar projects.

The need for power grows much faster for less developed nations than for those that already there is growing momentum for supplying electricity to developing regions using solar energy resource [6]. The solar energy technologies offer energy independence and sustainable development. Stand-alone solar and wind energy systems can provide cost effective, modest levels of power of lighting, communication, fans, refrigerators, water pumping etc. Installation of Photo Voltaic (PV) systems solely for remote site has expanded to include the promotion of rural economic development. PV system provides power for remote water pumping, refrigeration, and water treatment of community water supplies.

2.3 Solar energy and its importance

The need for power grows much faster for less developed nations than for those that already industrialized. The three decades of major investments by less developed nations and multilaterals on electrification projects, nearly 2 billion people in developing regions around the globe still lack electricity. Millions of people rely solely on kerosene lamps for lighting and disposable batteries for radios. For most of these people, there is little likelihood of ever receiving electricity from conventional grid sources. However, there is growing momentum in supplying electricity to developing regions using solar energy resource. The solar energy technologies offer energy independence and sustainable development by using renewable energy resources.

The cost of bringing utility power via transmission and distribution lines to non-electrified villages is great. This is largely due to small household electrical loads and the fact that many villages are located at great distances over difficult terrain from the existing grid. Stand-alone solar and wind energy systems can provide cost-effective, modest levels of power for lighting, communication, fans, refrigerators, water pumping, etc. Using a least-cost model, development tool for electrification planning as either centralized or distributed solutions. Two decades ago, PV technology was relatively unknown. Gradually throughout the developing world, small solar companies began to form as PV module manufacturers began to establish distributor networks to serve remote, non-electrified areas.

Approximately one-third of the world's population lives in rural regions without access to the electric grid, and about half of these same people live without access to safe and clean water. Solar energy is unique in that it can easily provide electricity and purified water for these people today with minimal infrastructure requirements by using local energy resources that promote local economic development.

Unfortunately, traditional fossil fuel energy use has had serious and growing negative environmental impacts, such as CO₂ emissions, global warming, air pollution, deforestation, and overall global environmental degradation. Additionally, fossil fuel reserves are not infinite or renewable; the supply is limited. Without a doubt, there will be significant changes in our society's modern energy infrastructure by the end of the twenty-first century.

The primary renewable energy sources are the Sun, wind, biomass, tides, waves, and the Earth's heat (geothermal). Solar energy is referred to as renewable and/or sustainable energy because it will be available as long as the Sun continues to shine. Estimates for the life of the main stage of the Sun are another 4 to 5 billion

years. Another aspect of solar energy is the conversion of sunlight into biomass by photosynthesis. Animal products such as whale oil and biogas from manure are derived from this form of solar energy. Fossil fuels are stored solar energy from past geological ages.

Even though the quantities of oil, natural gas, and coal are large, they are finite, and resources are sufficient to power the industrialized world anywhere from a few more decades to a few more centuries, depending on the resource. There are also large environmental costs associated with fossil fuel exploitation from habitat loss and destruction due to strip mining and oil spills to global warming of the atmosphere largely caused by the combustion by-product of carbon dioxide.

The advantages of renewable energy are many: sustainability (cannot be depleted), ubiquity (found everywhere across the world in contrast to fossil fuels and minerals), and essentially non-polluting and carbon free. Energy solutions for the future depend on local, national, and world policies. Solutions also depend on individual choices and the policies that we implement as a society. This does not mean that we have to live in caves to negate our energy inputs, but we do have to make wise energy choices and conserve by methods such as driving fuel-efficient vehicles and insulating our homes, to name a few. To overcome the twenty-first century perfect energy storm, we will all have to work together cooperatively while doing our individual parts.

Solar thermal energy is the technology used for harnessing solar energy for thermal energy. A solar thermal collector captures the radiant energy from the Sun and converts it into heat. More recently, in a wide variety of thermal processes solar energy has been developed for power generation, water heating, mechanical crop drying, and water purification, among others. A major benefit of solar thermal power is that it has little adverse environmental impact, with none of the polluting emissions or safety concerns associated with conventional generation technologies. There is hardly any pollution in the form of exhaust fumes or noise during operation. Decommissioning a system is not problematic. Solar collectors are a cheap and effective means of converting sunlight into thermal heat. This module discusses these two types of solar thermal collectors since they are commonly used in India.

Heat is simply a form of energy associated with the motion of molecules. When the electromagnetic waves coming from the Sun hit an object, they excite the molecules of that object causing them to move [18]. This molecular movement is heat. Heat is always moving from higher to lower temperatures until the temperatures are equal. This is known as heat transfer. If you place two objects next to each other, the warmer object will cool down as its heat is transferred to the cooler object. The cooler object in turn will warm up. This heat transfer is driven by

the difference in temperatures of the objects. The heat transfer rate is proportional to the difference in temperature. The larger the difference in temperature between the objects, the faster the heat moves.

2.4 Different method of use of Solar energy

Storage of solar energy :

Solar energy is a non dispatchable energy technology that only captures energy during daylight hours. Some type of energy storage is thus required to make the energy available during non sunny periods [54-56]. Energy storage can take several forms, most commonly electrochemical energy storage through batteries. But energy also can be stored in the form of compressed air, Pumped hydro storage, hydrogen, or thermal mass. Many types of batteries and charge controllers are used in standalone Photo Voltaic systems to provide energy when sun is not shining.

A storage battery is an electrochemical device. It stores chemical energy that can be released as electrical energy. When the battery is connected to an external load, the chemical energy is converted into electrical energy and current flows through the circuit.

It is important to understand that solar thermal technology is not the same as solar panel, or photovoltaic, technology. Solar thermal electric energy generation concentrates the light from the sun to create heat, and that heat is used to run a heat engine, which turns a generator to make electricity. The working fluid that is heated by the concentrated sunlight can be a liquid or a gas. Different working fluids include water, oil, salts, air, nitrogen, helium, etc. Different engine types include steam engines, gas turbines, Stirling engines, etc.

All of these engines can be quite efficient, often between 30% and 40%, and are capable of producing 10's to 100's of megawatts of power. Photovoltaic, or PV energy conversion, on the other hand, directly converts the sun's light into electricity. This means that solar panels are only effective during daylight hours because storing electricity is not a particularly efficient process. Heat storage is a far easier and efficient method, which is what makes solar thermal so attractive for large-scale energy production. Heat can be stored during the day and then converted into electricity at night. Solar thermal plants that have storage capacities can drastically improve both the economics and the dispatchability of solar electricity.

Solar pond :

Solar pond is an artificially constructed pond in which significant temperature rises are caused to occur in the lower regions by preventing convection. To prevent

convection, salt water is used in the pond. Those ponds are called “salt gradient solar pond”. In the last 15 years, many salt gradient solar ponds varying in size from a few hundred to a few thousand square meters of surface area have been built in several countries. Nowadays, mini solar ponds are also being constructed for various thermal applications.

A Salinity Gradient Solar Pond (SGSP) is a simple and low cost mean to collect and store solar energy in the high-density salt water. Therefore, in practice, a typical solar pond consists of three distinct zones. Two convective zones where the first is at the top (Upper Convective Zone, UCZ) and the second is at the bottom (Lower Convective Zone, LCZ). These two layers are separated by a salinity gradient (Non-Convective Zone, NCZ). Although the diffusion flux tends to homogenize the system, the maintenance of the salinity profile in the solar pond can be obtained by addition of brine at the LCZ and fresh water in the UCZ.

The solar pond (SP) is a shallow water body being virtually a trap for solar radiation. The trapped solar radiation is converted into thermal energy which is accumulated in the deep-water layers of the SP. The thermal energy can be accumulated due to the stabilizing salinity gradients existing in the SP, which prevent thermal convection in the water body. Proper operation of the SP depends on the ability to withdraw hot water by a selective withdrawal while preserving the density profile of the pond.

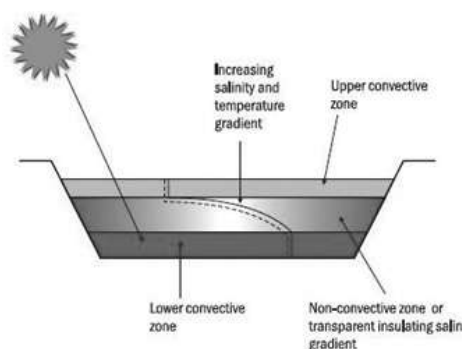

Fig 1.4.1 Diagram of Operation of Solar Pond

Applications of Solar Pond

The following applications are :

- Salt Production
- Aqua Culture
- Dairy Industry
- Fruit and Vegetable canning industry
- Grain industry
- Power generation
- Hot water production
- Water supply (for Desalination).

Solar water heater :

The most common use for solar thermal technology is for domestic water heating. Hundreds of thousands of domestic hot water systems are in use throughout the world. The main components of a solar water heater are the solar collector, storage, and heat distribution. Several configurations differ on the heat transport between the solar collector and the storage tank, as well as on the type of freeze protection [25]. The most successful solar heaters are the integrated collector and storage (ICS), thermosiphon, drain-back, and drain-down systems. These are habitually assisted in backup by a conventional system. In some countries, the installation of solar equipment must comply with local, state, and national building codes, roofing codes, plumbing codes, and national electrical codes.

The ICS and thermosiphon are passive solar water heaters where fluid circulation occurs by natural convection, as shown in the figure 1.4.2. The absorber's energy gained by solar radiation is transferred to the copper pipes. The inlet fluid is located at the bottom of the collector; as heat is captured, the water inside the pipes warms up. The hotter the water is, the less dense and better it is for circulation. When hot water travels toward the top, the cooler and denser water within the storage tank falls to replace the water in the collector. Under no or low insolation, circulation stops; the warm and less dense fluid stagnates within the tank. The ICS is a self-contained integration of a solar collector and solar heated water storage, usually holding 30-40 gallons in a tank. Both the ICS and the thermosiphon heaters are a low-cost alternative to an active-open-loop solar water system for milder climates. These systems have 40- to 120-gal storage tanks installed vertically or horizontally above the collector.

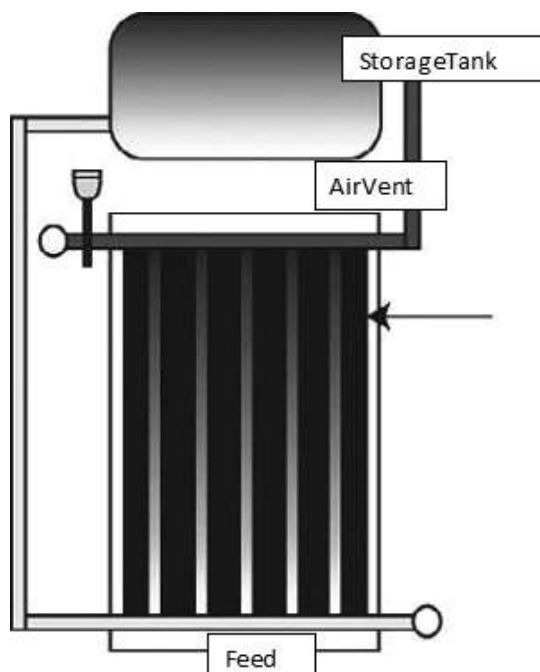

Fig 1.4.2 Solar water heater

Flat plate collector :

Solar collectors are distinguished as low, medium, or high-temperature heat exchangers. There are basically three types of thermal solar collectors: flat plate, evacuated tube, and concentrating [19]. Although there are great geometric

differences, their purpose remains the same: to convert the solar radiation into heat to satisfy some energy needs. The heat produced by solar collectors can supply energy demand directly or be stored. To match demand and production of energy, the thermal performance of the collector must be evaluated. The instantaneous useful energy collected the result of an energy balance on the solar collector.

To evaluate the amount of energy produced in a solar collector properly, it is necessary to consider the physical properties of the materials. Solar radiation, mostly short wavelength, passes through a translucent cover and strikes the energy receiver. Low-iron glass is commonly used as a glazing cover due to its high transmissivity; the cover also greatly reduces heat losses. The optical characteristics of the energy receiver must be as similar as possible to those of a blackbody, especially high absorptivity.

A solar collector works on the principle of converting solar energy into heat by taking advantage of a process known as the greenhouse effect. The basic idea is that the solar energy passes through a layer of glazed glass where it is absorbed by the underlying material. The solar energy excites the molecules in the underlying material resulting in heat. The glazing of the glass prevents the heat from escaping, thereby effectively capturing the heat. Once that heat is captured, we can put it to good use. But to use it, we first need to understand some of the basic principles of heat.

A flat-plate solar collector consists of a waterproof, metal or fiberglass insulated box containing a dark-coloured absorber plate, the energy receiver, with one or more translucent glazing's. Absorber plates are typically made from metal due to its high thermal conductivity and painted with special selective surface coatings to absorb and transfer heat better than regular black paint can. The glazing covers reduce the convection and radiation heat losses to the environment. These systems are always mounted in a fixed position optimizing the energy gain for the specific application and particular location. Flat collectors can be mounted on a roof, in the roof itself, or be freestanding.

Solar distillation :

Distillation is a process that allows purifying some components of a solution based on differences of volatilities. In general terms, when solutes have much smaller volatilities than the solvent, distillation is carried out by evaporating the solvent in a particular region of the device and then condensing the vapor in a different region to obtain as pure a solvent as possible. When conventional energy supply is replaced by solar radiation, the process is called solar distillation . For

the conventional process, the production rate remains constant under stable conditions of pressure, temperature, energy consumption, composition, and flow rate of the inlet stream. For the solar process, although predictable, it varies during a day, showing a maximum during the hours with the highest irradiance. The variation is not only hourly but also daily over the whole year.

The most widely used application for solar water distillation has been for water purification. The advantage of solar over conventional systems in the purification of simple substances, such as brine or well waters, is that operation and maintenance are minimal because no moving parts are involved [66-67]. Also, there is no consumption of fossil fuels in solar distillation, leading to zero greenhouse- gas emissions. Most importantly, these types of systems can be installed in remote sites to satisfy freshwater needs of small communities that do not have conventional electric service.

Solar distillation represents one of the simplest yet most effective solar thermal technologies. Currently, several solar still prototypes exist; differences lie in their geometries and construction materials. All designs are distinguished by the same operation principles and three elements: solar collector, evaporator, and condenser.

Solar cooker :

Over 80% of rural households use biofuels and animal dung for cooking. A vast majority of such homes burn firewood in traditional cook stoves (chulhas). This emits smoke and has adverse environmental and health effects. Additionally, the process of collecting firewood is often an exhausting and time-consuming task. While small-scale solar cooking will benefit individual families in terms of health, large-scale solar cooking has the potential to save considerable fossil fuel. Solar cooking has several advantages since it requires very little maintenance and saves cooking time and fuel cost.

The focus of this case study is on large-scale solar cooking applications with the solar steam cooker.

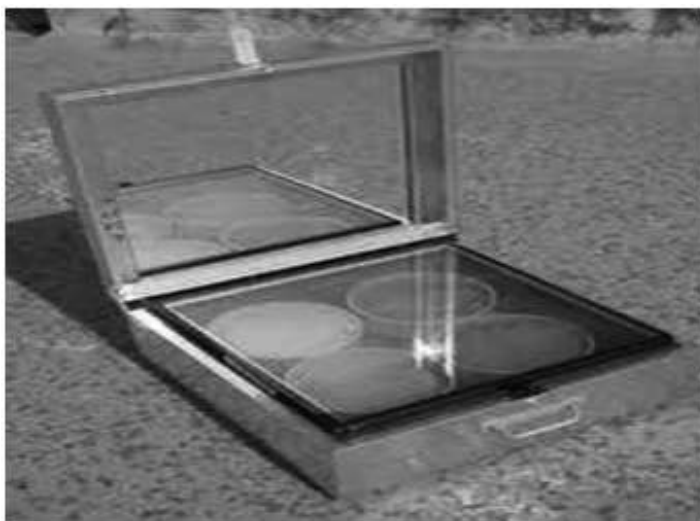

Schematic view of a Solar cooker

There are many large installations of solar cookers in India where several thousand meals are prepared daily. Solar cookers fall into two main categories - solar box and direct solar concentrators. The basic design for a solar box is that of a box with a glass cover. The box is lined with insulation and a reflective surface is applied to concentrate the heat onto the pots. The other approach is to reflect the sun's rays onto a pot, often with a parabolic dish. The pots can be painted black to help with heat absorption. The main advantage to solar cookers is that wood does not need to be purchased or collected, which is often a very time-consuming activity for women. Many variations of solar cooker have been developed from the very basic reflective cardboard sheet box to the very sophisticated large-scale institutional and commercial solar cookers now being used in India.

Solar green houses :

Solar greenhouses are the enclosures where crops, vegetables, or flowers are provided proper environment under adverse climatic conditions for plant growth and production. Certainly, all greenhouses receive necessary sunlight from the sun required for photosynthesis and also supplementary heat during cold months from sun. In tropical countries, the solar insolation and ambient temperatures are quite high and therefore summer greenhouses can be designed in such a way that the inside temperature remains low and the plants receive sufficient of sunlight required for photosynthesis. Greenhouses are also nowadays used for growing vegetables and flowers throughout the year even if their season is not there since the light and temperature in the greenhouses can be controlled. Some greenhouses are also designed to conserve the water resources. Naturally, each plant type requires a little different type of environment for best production, but basically the desirable needs are moderate temperature, light, carbon dioxide, oxygen, mineral nutrients, air movement and water. The greenhouses are generally made to provide two energy related needs which are moderate temperature and light. Temperature is a dominant environmental factor in plant growth and optimum temperatures must be maintained to obtain optimum conditions during all stages of plant growth. The temperature can be high but it should not be so high as to cause the metabolic change. The optimum temperature can be altered by changes in water relations, light intensity, etc. and is related with environmental factors. The light is absolutely essential for plant growth and development and the light intensity, light spectral distribution and its duration affects the plant growth.

Therefore one of the most essential requirement of a greenhouse is the light transmission of solar radiation through the greenhouse covers (glazings). Since in cold climates during the night times the inside temperature can go quite low, auxiliary heating is required for maintaining the optimum temperature, therefore

the greenhouse structure should be well insulated thermally to reduce the cost of auxiliary heating. Moreover, the greenhouse structure should have adequate strength to withstand the forces of wind, hail, and snow.

In a solar greenhouse, it is not only the light which is maintained at desired level but the solar heat is to be stored for use at night and for cloudy days, and therefore it differs from the ordinary glass house. In solar greenhouses, the solar energy is collected and stored in a variety of ways and therefore the solar greenhouses differ in their designs. Moreover, the solar collection storage system depends on many factors like climate, greenhouse size, plant type, orientation, economics, and weather a new green house is to be planned or existing is to be modified. Further there can be a design difference if the collection-storage and distribution system is by passive means or by active means. The former greenhouses where the energy is stored directly in heavy brick walls or rock walls and/or water pools or water containers exposed to solar radiation and heat is distributed inside the greenhouse by natural means are known as passive greenhouses. In greenhouses where solar energy is collected and stored and distributed and where some auxiliary energy is employed either for circulation or for distribution or for both are known as active type.

Generally a combination of both active and passive features are employed in a solar greenhouse with an objective to minimize the use of auxiliary energy either for heating the greenhouse or for collection-storage-distribution system.

One unique advantage of a solar greenhouse is the less use of the auxiliary energy required to maintain the indoor air temperature required for plant growth compared to that required in the conventional greenhouse. Other advantages of a solar greenhouse are: growing season can be extended practically for a year at a much lower operating cost than conventional greenhouses, relatively easy to build, uses simple technology and low in cost because of the use of low cost materials.

There are many materials recently developed, techniques perfected and designs developed which make a greenhouse cost effective in certain situations.

2.5 Solar cell and its application]

Solar cell :

Photovoltaic systems (PV system) use solar panels to convert sunlight into electricity. Photovoltaics provide practical solutions to many power supply problems in both space and remote terrestrial applications. In addition to larger

power applications, portable electronic devices may charge their batteries using solar cells or get their power directly from solar cells.

Electricity can be produced from sunlight through a process called the PV effect, where “photo” refers to light and “voltaic” to voltage. The term describes a process that produces direct electrical current from the radiant energy of the Sun. The PV effect can take place in solid, liquid, or gaseous material; however, it is in solids, especially semiconductor materials, that acceptable conversion efficiencies have been found. Solar cells are made from a variety of semiconductor materials and coated with special additives. The most widely used material for the various types of fabrication is crystalline silicon, representing over 90% of global commercial PV module production in its various forms.

A typical silicon cell, with a diameter of 4 in., can produce more than 1 W of direct current (DC) electrical power in full sun. Individual solar cells can be connected in series and parallel to obtain desired voltages and currents. These groups of cells are packaged into standard modules that protect the cells from the environment while providing useful voltages and currents.

PV modules are extremely reliable because they are solid state and have no moving parts. Silicon PV cells manufactured today can provide over 40 years of useful service life. A system is made up of one or more solar photovoltaic (PV) panels, a DC/AC power converter (also known as an inverter), a tracking system that holds the solar panels, electrical interconnections, and mounting for other components. Optionally it may include a maximum power point tracker (MPPT), battery system and charger, solar tracker, energy management software, solar concentrators, or other equipment.

Need and characteristics of photovoltaic (PV) systems :

Current-voltage (I-V) curves are obtained by exposing the cell to a constant level of light, while maintaining a constant cell temperature, varying the resistance of the load, and measuring the produced current. The I-V curve typically passes through two points:

- ❑ Short-circuit current (ISC) : ISC is the current produced when the positive and negative terminals of the cell are short-circuited, and the voltage between the terminals is zero, which corresponds to zero load resistance.
- ❑ Open-circuit voltage (VOC) : VOC is the voltage across the positive and negative terminals under open-circuit conditions, when the current is zero, which corresponds to infinite load resistance.

The cell may be operated over a wide range of voltages and currents. By varying the load resistance from zero (a short circuit) to infinity (an open circuit), the MPP of the cell can be determined. On the I-V curve, the maximum power point (Pm) occurs when the product of current and voltage is maximum. No power is produced at the short-circuit current with no voltage, or at the open-circuit voltage with no current. Therefore, MPP is somewhere between these two points. Maximum power is generated at about the “knee” of the curve. This point represents the maximum efficiency of the solar device in converting sunlight into electricity.

A PV system consists of many cells connected in series and parallel to provide the desired output terminal voltage and current. This PV system exhibits a nonlinear I-V characteristic. There are various models available to model the I-V characteristics of PV systems. The PV cell equivalent model, which represents the dynamic nonlinear I-V characteristics of the PV system described in Equation 1.1. The output voltage characteristic of the PV system can be expressed as

$$V_{PV} = \frac{N_s \alpha k T}{q} \ln \frac{I_{SC} - I_{PV} + N_p I_0}{N_p I_0} - N_s \frac{R_s I_{PV}}{N_p}$$

The parameters used in the PV output voltage equation are as follows :

α : ideality or completion factor

I_0 : PV cell reverse saturation current (A)

I_{PV} : PV cell output current (A)

I_{SC} : short-circuit cell current (representing insulation level) (A)

k : Boltzmann's constant (J/°K) (1.380×10^{-23})

M_v : voltage factor

N_p : number of parallel strings

N_s : number of series cells per string

q : electron in charge (C) (-1.602×10^{-19})

R_s : series resistance of PV cell (Ω)

T : PV cell temperature (°K)

V_{MP} : PV cell voltage corresponding to maximum power (V).

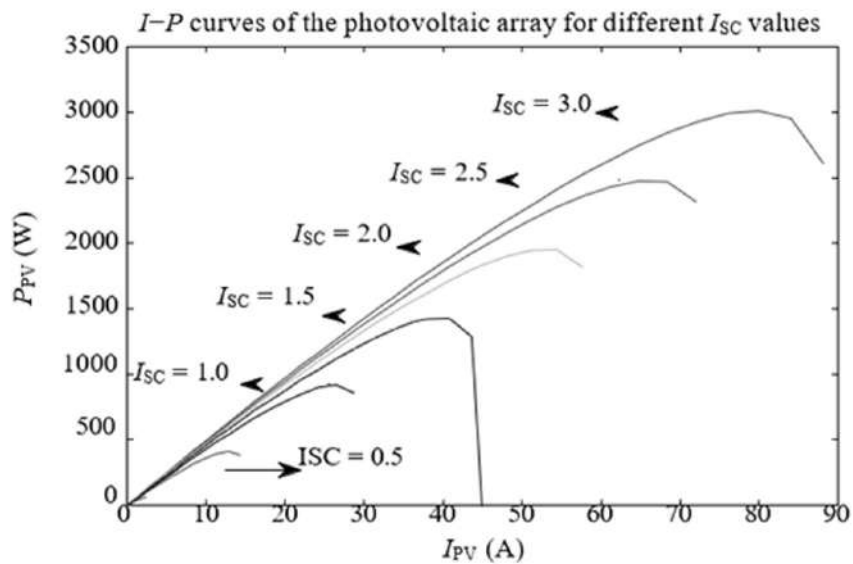
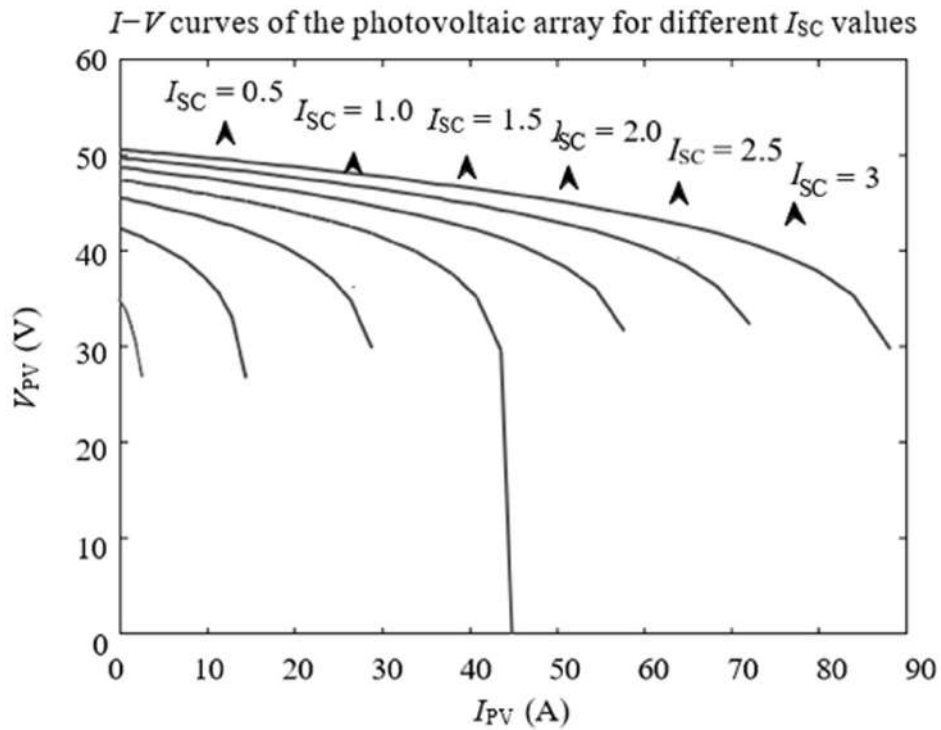

PV models and equivalent circuits :

Single-Diode and Dual-Diode Models

A PV model can be expressed by the equivalent circuit shown in Figure 1.5.1. This model is also known as a single-diode model.

In this model, open-circuit voltage and short-circuit current are the key parameters. The short-circuit current depends on illumination, while the open-circuit voltage is affected by the material and temperature. In this model, V_T is the temperature voltage expressed as $V_T = kT/q$, which is 25.7 mV at 25°C. The ideality factor n generally varies between 1 and 5 for this model. The equations defining this model are

$$I_D = I_0 e^{V_{PV}/\alpha V_T} - 1$$

$$I_{PV} = I_{SC} - I_D$$

$$V_{PV} = \alpha V_T \ln \left(\frac{I_{SC} - I_{PV}}{I_0} + 1 \right)$$

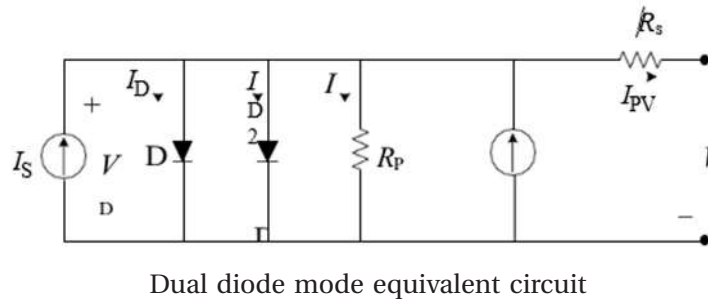
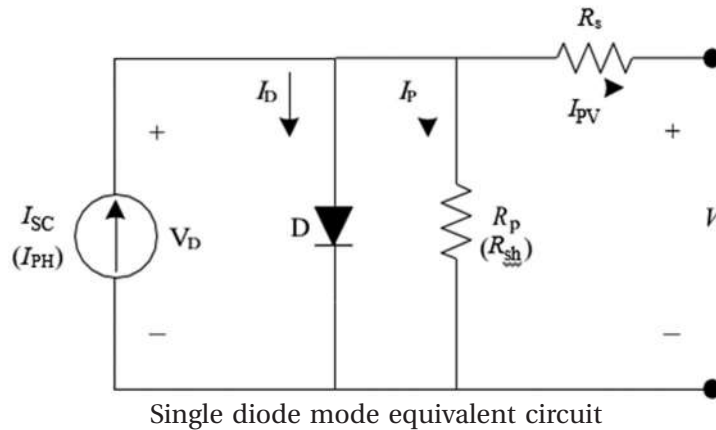

The I-V characteristic of the solar cell can be alternatively defined by

$$I_{PV} = I_{PH} - I_D$$

$$= I_{PH} - I_0 \exp \left(\frac{q(V + R_s I_{PV})}{\alpha k T} \right) - 1 - \frac{V_{PV} + R_s I_{PV}}{R_p} \quad (1.5)$$

where I_{PH} is photocurrent (A), I_D is diode current (A), R_s is series resistance, and R_p is parallel resistance.

An alternative model for PV cells is the dual-diode model, presented in Figure 1.8. In the dual-diode model, extra degrees of freedom are provided for accuracy. However, the first model is widely used for PV applications since it is sufficient to

represent PV characteristics and dynamics. Although it has more accuracy, this dual-diode model is not widely used due to its complexity.

sun tracking systems :

The sun changes its position from morning to night and from one season to another. A sun tracker is an apparatus that is used for orienting a solar PV panel, concentrating a solar reflector or lens toward the sun. Solar panels require a high degree of accuracy to ensure that the concentrated sunlight is directed precisely to the PV device. Solar tracking systems can substantially improve the amount of power produced by a system by enhancing morning and afternoon performance. Strong afternoon performance is particularly desirable for grid-tied PV systems, as production at this time will match the peak power demand period for the summer season. A fixed system oriented to optimize this limited time performance will have a relatively low annual production because the PV panels are fixed and do not move to track the sun.

For low-temperature solar thermal applications, trackers are not usually used. This is because tracking systems are more expensive when compared to the cost of adding more collectors. In addition, more restricted solar angles are required for winter performance, which influences the average year-round system capacity. For solar-electric applications, trackers can be relatively inexpensive when compared to the cost of a PV system. This makes them very effective for PV systems in high-efficiency panels. From the maintenance point of view, solar trackers need to be inspected and lubricated on an annual or seasonal basis.

There are several techniques to track the position of the sun and adjust the position of the panel. One of the most common techniques of tracking the sun is to use the relationship between the angle of the light source and the differential current generated in two close photodiodes due to the shadow produced by a cover over them.

The structure of the sun tracking system based on the relationship between the angle of light and the differential current in two photodiodes is demonstrated in Figure 1.4. The shadow over the photodiodes will be generated by the cover when the light source is misaligned. As a result, one photodiode is more illuminated than the other. The more illuminated photodiode generates more electrons

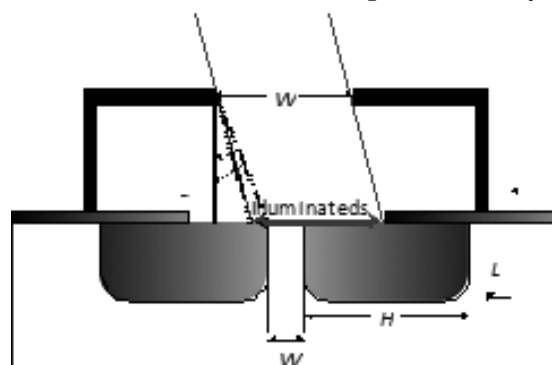

Fig. 1.4 The structure of the sun tracking system based on angle of the light using two photodiodes.

than the other one. Therefore, the difference between the generated currents becomes larger as the misalignment angle increases. The system can use the difference between these currents to orientate the system to directly face the sun.

Dynamic range is the parameter that the sun tracking system responds to in threshold limits. The distance between both modules does not have to limit the dynamic range. If the dynamic range is increased, the sensitivity of the current differences decreases. Therefore, between the dynamic range and the sensitivity, there is a trade-off. As a solution, two parallel sensors can be operated to reach the desired sensitivity and high dynamic range in an optimum manner.

2.6 Summary

Solar energy is one of the main source of harvesting energy and use it in our daily life. Solar cell, solar cooker, solar pond eta are beig used to harvest energy from this source.

2.7 Questions

1. What is solar cell
2. What is energy storage devices?
3. In which factors the efficiency of a solar cell depends?
4. What is single diode and dual diode equivalent circuit of a solar cell?

Unit 3 Wind Energy Harvesting

Contents

- 3.1 Objective**
- 3.2 Introduction**
- 3.3 Fundamentals of Wind energy**
- 3.4 Wind Turbines and different and electrical machines in wind turbines**
- 3.5 Summary**
- 3.6 Questions**

3.1 Objective

By learning this unit you will gather knowledge about wind energy and its use. It will help you to understand the potential of renewable energy source that human being may harvest in next century.

3.2 Introduction

Wind is the airflow that consists of many gases in the atmosphere of the earth. Rotation of the earth, uneven heating of the atmosphere, and the irregularities of the ground surface are the main factors that create winds. Motion energy of the wind flow is used by humans for many purposes such as water pumping, grain milling, and generating electricity. Windmills that are used for electricity generation are called wind turbines in order to distinguish them from the traditional mechanical wind power applications.

Wind is a sustainable energy source since it is renewable, widely distributed, and plentiful. In addition, it contributes to reducing the greenhouse gas emissions since it can be used as an alternative to fossil-fuel-based power generation. Wind turbines capture the kinetic energy of winds and convert it into a usable form of energy. The kinetic energy of winds rotates the blades of a wind turbine. The blades are connected to a shaft. The shaft is coupled to an electric generator. The generator converts the mechanical power into electrical power. Even though wind turbines currently provide only 1% of the worldwide power supply, wind energy is one of the fastest growing renewable energy technologies all over the world. In countries such as Denmark, Spain, Portugal, and Germany, wind power accounts for approximately 19%, 9%, 9%, and 6% of the required electric power, respectively. From 2000 to 2007, the global wind power generation increased to approximately five times of its previously recorded capacity.

Wind energy conversion systems (WECS) involve many fields of various disciplines such as kinematics, mechanics, aerodynamics, meteorology, power electronics, power systems, as well as topics covered by structural and civil engineering.

3.3 Fundamentals of Wind energy

The wind is the phenomenon of air moving from the equatorial regions toward the poles, as light warm air rises toward the atmosphere, while heavier cool air descends toward the earth's surface. Therefore, cooler air moves from the North Pole toward the Equator and warms up on its way, while already warm air rises toward the North Pole and gets cooler and heavier, until it starts sinking back down toward the poles. Another phenomenon that is affecting global winds is caused by the "Coriolis force," which makes all winds on the northern hemisphere divert to the right and all winds from the southern hemisphere divert to the left.

Both of the above-mentioned phenomena affect global winds that exist on the earth's surface. Hence, as the wind rises from the Equator, there will be a low-pressure area close to ground level attracting winds from the North and South. At the poles, there will be high pressure due to the cooling of the air. In order to find the most suitable sites for wind turbines, it is crucial to study the geological data of the area since the wind's speed and direction are highly influenced by the local topology. Surface roughness and obstacles not only will affect the speed of the wind, but also affect its direction and overall power.

During the daytime, land masses are heated by the sun faster than water bodies due to their higher specific densities, which allows them to have better heat transfer capabilities. Thus, during the day, air rises from the land, flows out to the sea, and creates a low-pressure area at ground level, which attracts the cool air from the sea. At nightfall, there is often a calm period when the land and sea temperatures are equal. During the night, the high pressure is inland, and the wind blows in the opposite direction.

In order to efficiently capture wind energy, several key parameters need to be considered: air density, area of the blades, wind speed, and rotor area. The force of the wind is stronger at higher air densities. Wind force generates torque, which causes the blades of the wind turbine to rotate. Therefore, the kinetic energy of the wind depends on air density; therefore heavier (denser) winds carry more kinetic energy. At normal atmospheric pressure and at 15°C (59°F), the weight of the air is 1.225 kg/m³, but if the humidity increases, the density decreases slightly. Air density is also influenced by temperature; therefore warmer winds are less dense than cold ones, so at high altitudes the air is less dense.

In addition, the area of the blades (air-swept area), that is, the diameter of the blade, plays an important role in the captured wind energy. The longer the blade, the bigger the rotor area of the wind turbine, and therefore, more wind can be captured under the same conditions.

The other parameter is the wind speed. It is expected that wind kinetic energy rises as wind speed increases.

The kinetic energy of the wind can be expressed as

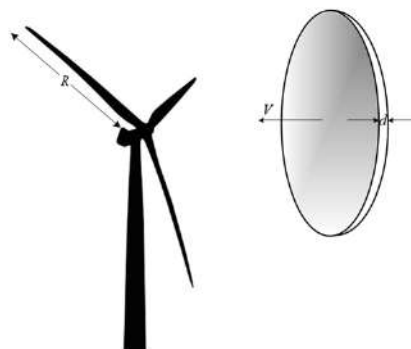

Fig 3.1 A schematic diagram of wind turbine

$$E_k = \frac{1}{2} m v^2 = \frac{1}{2} \rho V v^2 = \frac{1}{2} \rho A d v^2 = \frac{1}{2} \rho R^2 \pi d v^2$$

where E_k is the wind kinetic energy, m is the wind mass, v is the wind speed, ρ is the air density, A is the rotor area, R is the blade length, and d is the thickness of the “air disc” shown in Figure 3.1.

Hence, the overall power of wind (P) is

$$P = \frac{E_k}{t} = \frac{1}{2} \rho R^2 \pi \frac{d}{t} v^2 = \frac{1}{2} \rho R^2 \pi v^3$$

$$P = \frac{1}{2} \rho R^2 \pi v^3$$

The power content of the wind varies with the cube (the third power) of the average wind speed.

3.4 Wind Turbines and different and electrical machines in wind turbines

The blades are the main components that capture the kinetic energy of the wind and help the turbine rotate. The rotor is the part that couples the generator to the rotating part of the turbine, directly or through gearboxes. The pitch is the ability to change the wind-facing angle of the blades in order to maintain a constant wind turbine speed if the wind speed changes. With different pitch angles, the effective blade surface facing the wind direction can be controlled. For nominal speed, the pitch angle can be set to zero so that the blades fully face the upcoming wind. Above the nominal speed, the pitch angle can be increased; thus the effective blade surface is decreased and eventually a constant speed can be maintained.

The brake is the mechanical speed reducer that prevents the generator speed from increasing above the maximum value. Even though the pitch for the blades can be helpful for speed reduction, the brakes have a faster response than that of the pitch control. The low-speed shaft is connected to a gearbox with a high turn ratio that provides faster rotating speed to the generator during low wind speed conditions. The gearbox is the component that allows the wind turbine shaft to be coupled to the generator shaft. The generator is the mechanical-to-electrical energy conversion unit of the system that is driven by the mechanical power of the turbine. The electrical output of the generator is connected to the grid or load through power electronic converters. The controller, which is the brain of the system, is responsible for the torque and the speed control of the generator, determines the pitch angle, controls the yaw motor to face the wind direction, and controls the power electronic interfaces. The anemometer is a measurement device to assess the wind speed. The wind vane is an elevated device that shows the direction of the wind. This instrument may also be operated together with the yaw mechanism to measure the wind direction. The nacelle is the enclosure of the system and all of the generating components such as the generator, drive train, and the like are placed inside of the nacelle. The high-speed shaft drives the generator without a gearbox and it is essentially a gearbox with a turn ratio that is smaller than that of the low-speed shaft. It is effective during high-wind-speed conditions. The yaw drive ensures that the rotor is aligned with the wind direction. It helps produce the maximal amount of energy at all times by keeping the turbine facing the wind as its direction changes. The yaw motor is the device that provides mechanical rotation to the yaw drive for the yaw mechanism's operation. The tower supports the body of the turbine and the other components.

The main purpose of the tower is to support the nacelle and resist vibration due to the wind speed variations. The cables that connect the generator (on top of the tower, inside the nacelle) and transmission line (down, in the basement of the tower) are inside the tower. The tower is the main component that carries most of the other components such as the turbine, nacelle, blades, generator, and so on.

The height of the tower is different for offshore and onshore turbines. The higher towers are more appropriate for wind energy harvesting, since winds contain less turbulence in higher altitudes. However, stability issues limit the height of the tower. Onshore wind systems have higher towers than offshore turbines, because the land has higher roughness than the water surface. On the water surface, there are almost no obstacles; hence the low tower length is sufficient to capture the wind. In onshore applications, there may be some objects around the tower that may block the wind speed. In areas with high roughness, high turbine towers are required to avoid the effect of wind blocking objects such as buildings, mountains,

hills, trees, and so on.

The yaw mechanism is composed of the yaw motor and the yaw drive. The “yaw” mechanism turns the whole nacelle toward the wind direction in order to face the wind directly. Regardless of the direction of the wind, the yaw mechanism can help the turbine face the wind by changing the direction of the nacelle and the blades. During the rotation of the nacelle, there is a possibility of twisting the cables inside of the tower. The cables will become more and more twisted if the turbine keeps turning in the same direction, which can happen if the wind keeps changing in the same direction. The wind turbine is therefore equipped with a cable twist counter, which notifies the controller that it is time to straighten the cables.

The gearbox, generator, and the control electronics are all located inside of the nacelle. The nacelle is connected to the tower through the yaw mechanism. Inside the nacelle, two shafts connect the rotor of the turbine to the rotor of the electrical generator through the gearbox. The gearbox is the mechanical energy converter that connects the low-speed shaft of the turbine to the high-speed shaft of the electrical machine.

The control electronics inside the nacelle record the wind speed, direction data, rotor speed, and generator load, and then determine the control parameters of the wind operation system. If the wind changes direction, the controller will send a command to the yaw system to turn the whole nacelle and turbine to face the wind.

The electrical generator is the main part of the nacelle. It is the heaviest part and produces electrical energy, which is transferred through the cables to the grid. There are different types of generators that are used for wind turbines, and depending on the type of generator, wind turbines can operate with either fixed or variable speeds. Fixed speed (FS) turbines use synchronous machines and operate at an FS that depends on the grid’s frequency. These machines are not the best solution for the wind turbines, because the wind always changes its speed. Variable speed turbines use DC machines, brushless DC (BLDC) machines, and induction machines. DC machines are not commonly used due to the maintenance problems with the brushes. Induction and BLDC machines are more suitable for wind applications.

The turbine, also called “low-speed rotor,” usually has two to six blades. The most common number of blades is three since they can be positioned symmetrically, maintain the system’s lightness, and ensure the stability of the wind power system (WPS). Two-blade turbines have high stresses in cut-in speed; therefore, the speed and power of the wind are insufficient for starting the rotation of the turbine and

higher minimum wind speed values are required at the beginning. The radius of the blades is directly proportional to the amount of captured energy from the wind; hence an increased blade radius would result in a higher amount of captured energy.

The blades are aerodynamic and they are made of a composite material such as carbon or Plexiglas, and are designed to be as light as possible. Blades use lift and drag forces caused by wind; therefore, by capturing these forces, the whole turbine will rotate. The blades can rotate around their longitudinal axis to control the amount of captured wind energy. This is called “pitch control.” If the wind speed increases, the pitch control can be used to change the effective blade surface, hence keeping the turbine power constant. The pitch angle control is usually used for wind speeds above the nominal speed.

3.4.1 Wind Turbines :

Wind turbines can be classified based on several criteria. One classification is based on the position of rotational axis and the other one is based on the size of the wind turbine.

Wind Turbines Based on Axis Position

Based on axis position, wind turbines are classified as the horizontal axis and vertical axis turbines.

Horizontal axis wind turbines (HAWTs) are more common than vertical axis wind turbines (VAWTs). The horizontal axis turbines have a horizontally positioned shaft, which helps ease the conversion of the wind’s linear energy into a rotational one.

VAWTs have a few advantages over the horizontal axis wind turbines. VAWTs’ electrical machines and gearbox can be installed at the bottom of the tower, on the ground, whereas in HAWTs, these components have to be installed at the top of the tower, which requires additional stabilizing structure for the system. Another advantage of the VAWTs is that they do not need the yaw mechanism since the generator does not depend on the wind direction. The most famous design of VAWT is Darrieus type of turbine.

There are a few disadvantages that limit the utilization of the VAWTs. Due to the design of blades, the sweep area of VAWT is much smaller. Wind speed is low near the surface and usually turbulent; hence these wind turbines harvest less energy than horizontal axis ones. Additionally, VAWTs are not self-starting machines and must be started in motoring mode, and then switched to generating mode.

Wind Turbines Based on Power Capacity

Another classification criterion for wind turbines is based on their installed

power capacity. Based on the installed power capacity, wind turbines are divided into small, medium, and large wind turbines.

The output power rating of small wind turbines is less than 20 kW. Small wind turbines are used for residential applications, supplying households with electricity, and they are designed for low cut-in wind speeds (generally 3-4 m/s). They are also suitable for remote places, where the grid is far away and the power transmission is difficult. Small wind generators provide isolated power systems for a household's load, and are usually connected to batteries, as shown in Figure 3.4.2 It is projected that small wind turbines would contribute to 3% of U.S. electrical consumption by 2020.

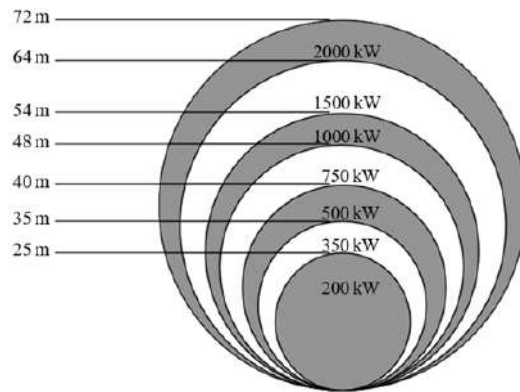

Fig 3.4.1 Turbine output power for different wind turbine diameters.

Medium wind turbines usually provide between 20 and 300 kW installed power. They are usually used to supply either remote loads that need more electrical power or commercial buildings. Medium wind turbines usually have a blade diameter of 7-20 m, and the tower is not higher than 40 m. They are almost never connected to a battery system. They are directly connected to the load through DC/AC power electronic inverters.

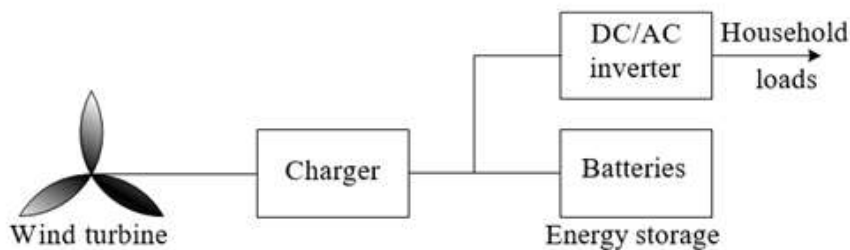

Fig. 3.4.2 Connection scheme of a typical small wind turbine.

Large wind turbines are of MW power range. These turbines incorporate complex systems, and wind farms typically consist of several to hundreds of those large turbines. One of the world's biggest wind turbines is located in Emden, Germany, built by the German company Enercon as an offshore turbine. The price of 1 kW installed power from a large wind turbine is significantly less than the price of 1 kW from a small turbine. Currently, the installed price of a large turbine is about Rs 50000/kW, and the price of energy is around Rs 40/kWh, depending on the site

and turbine size. Enercon turbines have a power output of 5 MW with a rotor blade diameter of 126 m, sweeping an area of over 12,000 m².

Different Electrical Machines in Wind Turbines

There are various types of electrical machines that are used in wind turbines. There is no clear criterion for choosing a particular machine to work as a wind generator. The wind generator can be chosen based on the installed power, site of the turbine, load type, and simplicity of control. BLDC generators, permanent magnet synchronous generators (PMSGs), induction generators, and synchronous generators are the machine types that are used in wind turbine application.

Squirrel cage induction or BLDC generators are generally used for small wind turbines in household applications. Doubly fed induction generators (DFIGs) are usually used for megawatt size turbines. Synchronous machines and permanent magnet synchronous machines (PMSMs) are the other machines that are used for various wind turbine applications.

BLDC Machines

Advancements over the course of the past 15-20 years in the development of the BLDC machines have made them very popular for multiple applications. In addition, the development of fast semiconductor switches, cost-effective DSP processors, and other microcontrollers have benefited the improvement of the motor/generator drives.

BLDC machines are widely used in small wind turbines (up to 15 kW) due to their control simplicity, compactness, lightness, ease of cooling, low noise levels, and low maintenance. Due to the existence of a magnetic source inside the BLDCs, they are the most efficient electric machines. Recent introduction of high-energy density magnets (rare-earth magnets) has allowed the achievement of very high flux densities in these machines bringing compactness. There is no current circulation in the rotor for the magnetic field; therefore, the rotor of a BLDC generator does not heat up. The absence of brushes, mechanical commutators, and slip rings suppresses the need for regular maintenance and suppresses the risk of failure associated with these elements. Moreover, there is no noise associated with the mechanical contact. The switching frequency of the driving converter is high enough so that the harmonics are not audible.

Due to its mechanical performance, the BLDC generator drive system can provide additional increase in power density with the advanced control techniques.

Since the BLDC generator has permanent magnets (PMs) inside the machine, it can be classified as a kind of PM machine. Due to the existence of PMs, the brushes and commutator, which supply magnetic flux in a regular DC machine, are not

required. Eddy current losses are also reduced since the stator has laminated steel. A trapezoidal electromotive force (EMF) is induced in the stator winding as the rotor rotates.

The waveform of the induced EMF from the stator winding is shown in Figure 3.4.3. The concentric winding of the machine and rectangular distribution of the magnetic flux in the air gap generate this nonsinusoidal EMF. Due to this waveform, a BLDC generator has approximately 15% higher power density in comparison to a PMSG, which has a sinusoidal winding configuration and sinusoidal magnetic flux distribution in the air gap. This is due to the fact that the effective time-integral of a trapezoidal waveform, which is proportional to the output power of the generator, is higher than that of a sinusoidal waveform with the same amplitude.

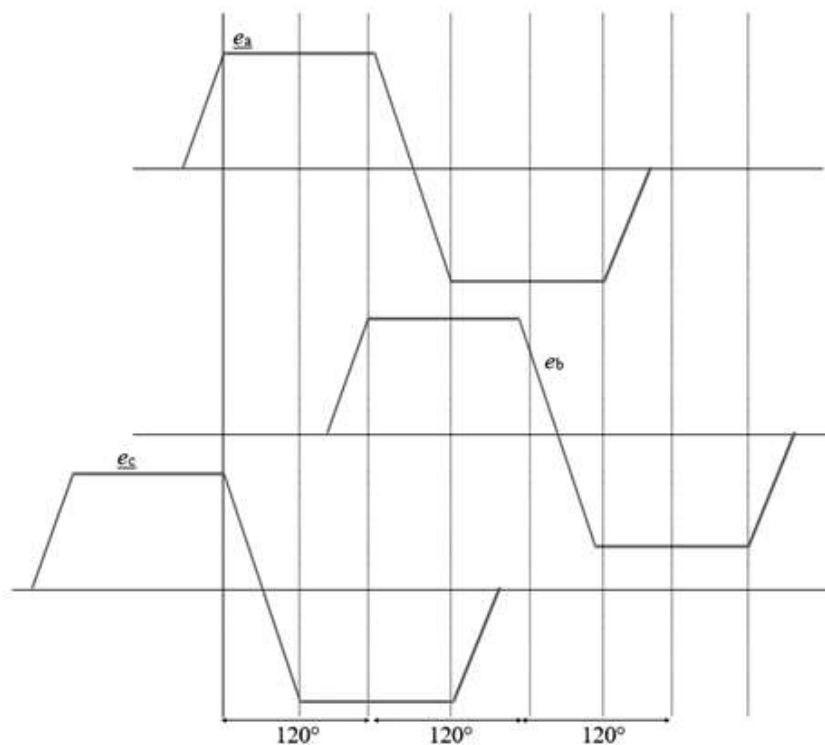

Fig. 3.4.3 Induced EMF of a three-phase BLDC generator.

Induction Machines

Three-phase induction machines are generally used in motor applications. However, they can also be effectively used as generators in electrical power systems. The main issue with induction machines used as electric power generators is the need for an external reactive power source that will excite the induction machine, which is certainly not required for synchronous machines in similar applications.

If the induction machine is connected to the grid, the required reactive power can be provided by the power system. The induction machine may be used in cogeneration with other synchronous generators or the excitation can be supplied from capacitor banks (only for stand-alone self-excited generators application).

Voltage and Frequency Control with Load Regulation

By employing a variable impedance controller, as shown in 3.4.5, the turbine speed governor can be eliminated and the efficiency of the system can be increased. Through this method, voltage and frequency control is achieved by using an impedance controller through a bridge rectifier, chopper, and a DC side resistor R_{dc} . A large AC capacitor bank is used to meet the power demand at the desired power factor.

The main purpose of an impedance controller is to keep the total real and reactive powers at a constant level. In the case of any load changes, the impedance controller will absorb the active or reactive power, which has not been used by the load. The excess power will be redirected to R_{dc} and will be consumed on this resistance. Thus, the total reactance of the system is adjusted as a function of the duty cycle of the chopper switch as shown in Figure 3.4.5. On the other hand, the excess power, which is not absorbed by the load, will be released through the resistor. Therefore, the prime mover requires no regulation and can always be operated at the required power, voltage, and frequency.

The impedance controller can regulate the voltage and frequency of the induction generator more efficiently than the conventional control

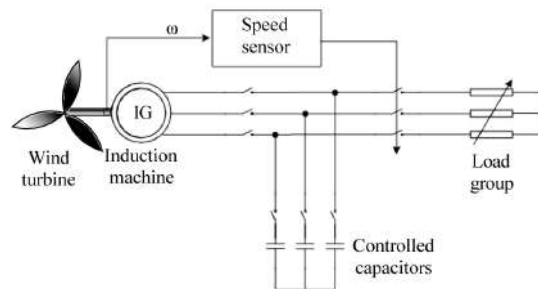

Fig. 3.4.4 Conventional control scheme for the induction generator.

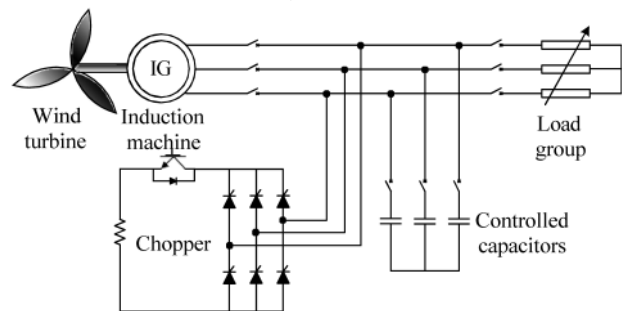

Fig. 3.4.5 Induction generator voltage and frequency control with load regulation.

strategy. However, the excess energy is consumed in the R_{dc} resistance, without effectively being used. Using the excess energy in storage devices or injecting it to the grid would be a more efficient solution for load regulation. The main concern is the need of large AC capacitors that provide the required reactive power for the excitation process.

3.5 Summary

Another source of energy is wind. Now a days wind turbines are used to generate electricity in commercial and small scale. As its available throughout the year. Only limitation it needs an average speed to et sustainable energy from it.

3.6 Questions

1. What is wind energy ?
2. How and where it can be harvested ?
3. What is the main part of a wind turbine ?

Unit 4 Ocean Energy

Contents

- 4.1 Objective**
- 4.2 Introduction**
- 4.3 Ocean Energy Potential against Wind and Solar**
- 4.4 Wave Characteristics and Statistics**
- 4.5 Wave Energy Devices**
- 4.6 Tide characteristics and Statistics and Tide Energy Technologies**
- 4.7 Ocean Thermal Energy, Osmotic Power, Ocean Bio-mass**
- 4.8 Summary**
- 4.9 Questions**

4.1 Objective

It is the primary target to understand the huge potential of ocean energy system as well as to understand the wave energy device and also use of tidal energy.

4.2 Introduction

Ocean energy, which is an indirect form of solar energy, is a very large resource. The development and demonstration of ocean energy technology has been suffering all along because of high cost of plant structures and offshore infrastructure. The sharp increase in the oil prices has highlighted, once again, the need to develop large-scale renewable energies including ocean energy.

The three forms of ocean energy conversion systems available today

- i. Ocean thermal energy conversion (OTEC)
- ii. Wave energy conversion (WEC)
- iii. Tidal energy conversion (TEC)

The highest priority of ocean technologists today is to calculate the viability of ocean energy plants vs fossil fuel plants.

4.3 Ocean Energy Potential against Wind and Solar

The potential of ocean energy in different regions depends on their geographical location with respect to the equator. Countries closer to the equator having tropical

seas around them have good potential for OTEC and countries in northern and southern latitudes have a good potential for wave energy. Tidal energy, caused by gravitational pull of moon and sun on the ocean mass of water, is high only in estuaries and bays where the tidal oscillations are amplified.

OTEC utilizes the temperature-difference between warm surface sea water of around 27-29°C in tropical waters and the cold deep sea water of around 5-7°C, which is available at a depth of 800 to 1000 m, to run a heat engine under Rankine cycle. This temperature differential worldwide and typical temperature depth profiles are shown in Fig 4.3.1.

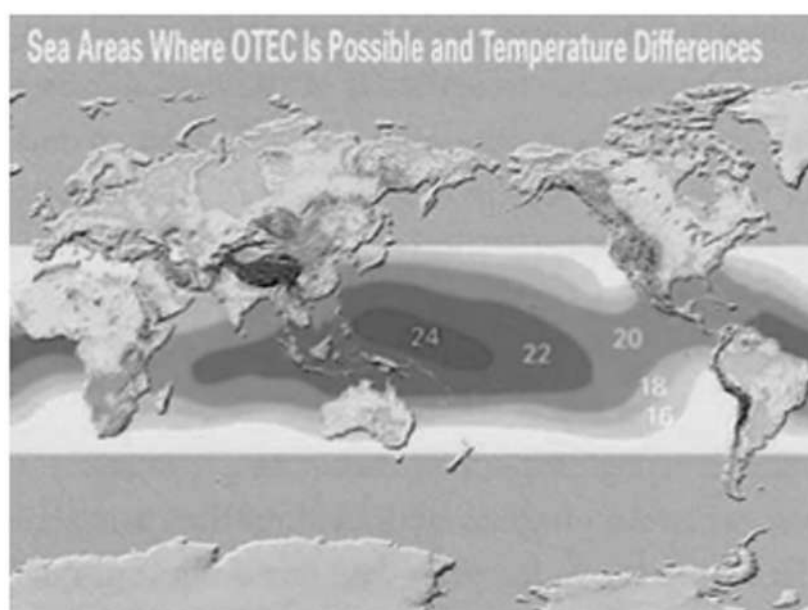

Fig 4.3.1 temperature differential worldwide and typical temperature depth

The warm surface water exchanges energy with low temperature boiling fluids such as ammonia and the vapour generated is passed through a turbine to produce work. The vapour, after expansion in the turbine, is condensed using deep sea cold water and re-circulated. This is how a closed cycle OTEC plant, which can easily be scaled to MW range, operates.

4.4 Wave Characteristics and Statistics

Ocean waves have the following characteristics

- **Crest** : the highest point of a wave
- **Trough** : the lowest point of a wave
- **Height** : the distance between a wave's crest and trough

- **Amplitude** : the distance between the crest or the trough to the still water line in between
- **Period** : the time between successive swell crests
- **Frequency** : the number of waves that cross a fixed point in a given amount of time

Ocean waves are following types

Wind waves

Wind waves are caused by the friction between local winds and surface water. They are directly caused by the wind in that location.



Swell waves

Over time and distance, sustained wind strength and duration build up a large amount of energy beneath the ocean's surface, forming deeper waves known as swells. Such energy can enable swells to travel thousands of miles across the ocean without changes in height or shape, until they reach a distant shore as breaking waves. Swell waves are an example of gravity waves, or oscillations of matter driven by gravitational force.



Tidal waves

Tidal waves are generated by ocean tides and therefore indirectly by the gravitational forces of the moon and sun. Tidal waves are considered predictable events because ocean tides are predictable events. The terms “tidal waves” and “tsunamis” are sometimes used interchangeably, but this is not technically accurate.

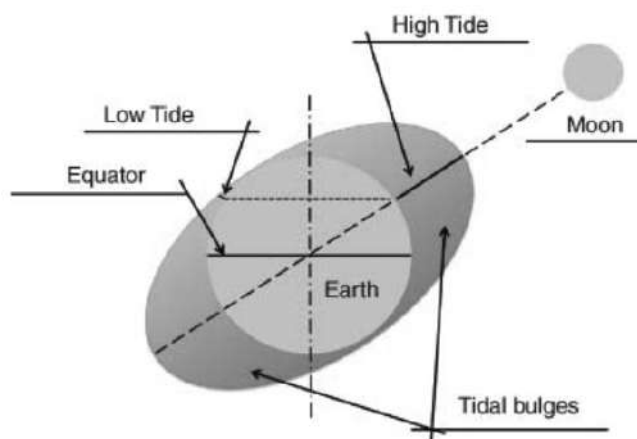

Tsunamis

Tsunamis are long-period oceanic waves driven by gravitational force. They are typically generated by an underwater geological event, such as an earthquake,

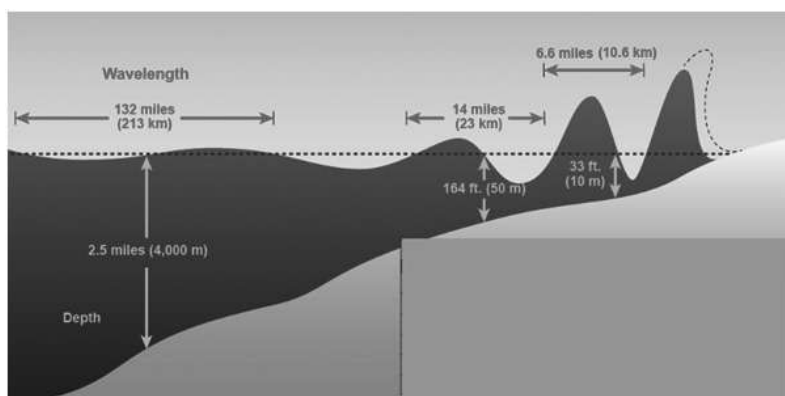

volcanic eruption, or a submarine landslide. Melting glaciers can also induce landslides which have the potential to generate tsunamis. The resulting abrupt change in sea-surface height from such an event sends a set of long waves propagating outward from the point of origin. As the waves approach the coastline and the water shoals, they are amplified and can be extremely destructive, depending on the shape of the coastline and the bathymetry (the underwater

equivalent of topography). In particular, as the tsunami enters the shoaling water, the wavelength shortens, the speed decreases, and the amplitude increases, whilst the period remains constant.

4.5 Wave Energy Devices

Today about 93 percent of the world's energy consumption relies on non-renewable energy sources such as oil and coal. The burning of these fossil fuels releases pollutants into the atmosphere and can result in environmental damage. Renewable energy sources, such as wind, solar, and wave, are possible alternatives to fossil fuels.

There are several devices to convert wave energy into electrical energy. Following are the latest device used in recent

Wave Attenuator

This device is long and multi-segmented and floats on the surface. The attenuator is anchored in place with a mooring line and positioned perpendicularly to incoming waves. Some attenuators tap only the heave (vertical motion); others tap both heave and surge. The device captures energy as the motion of the wave causes it to flex where the segments connect. This movement then drives hydraulic pumps or generators.



Point Absorber

The point absorber is a floating structure that captures energy from the vertical motion of the waves. This up-and-down motion of the device drives generators that create an electric current.

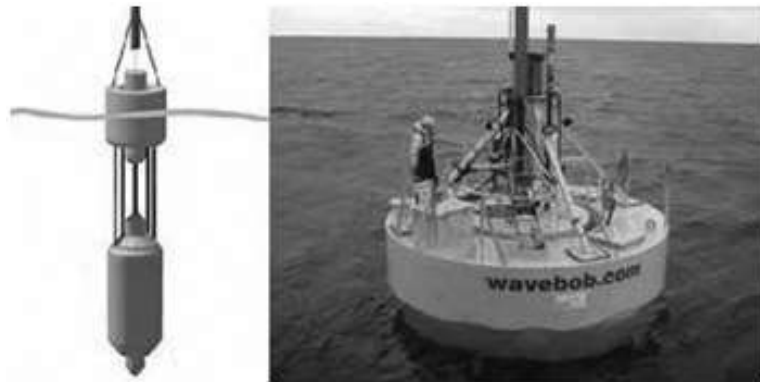

Surge Converter

This style of device harnesses wave energy directly from the surging and swelling motion of waves. It uses the oscillation between a float, flap, or membrane and a fixed point. That movement creates a usable form of mechanical energy. Similar devices are also being developed that utilize pitching, heaving, and swaying motions.

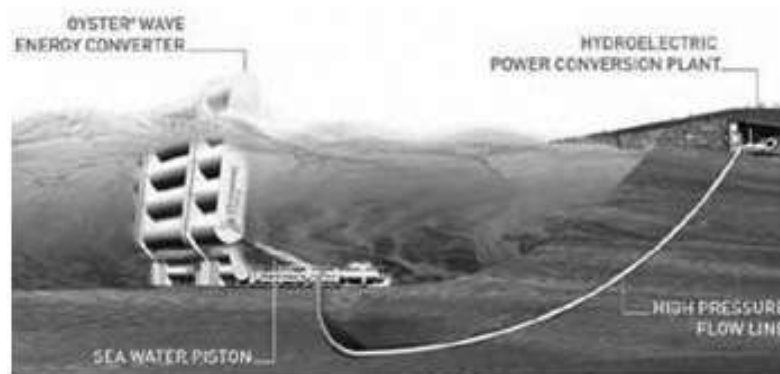

Overtopping Device

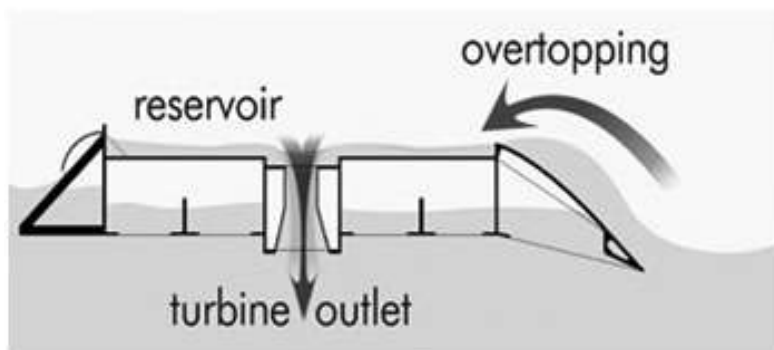

The overtopping device generally is constructed on shore or on a levee. There

is a collector that funnels waves over the top of the structure and into one of the device's reservoirs positioned below the waterline. The water is then run back out to sea through one or more turbines. As the water spins the turbine rotors, electric current is generated.

Oscillating Water Columns

This movement in the above figure both pressurizes and depressurizes the air column, moving a bidirectional turbine with the resulting “push/pull” force.

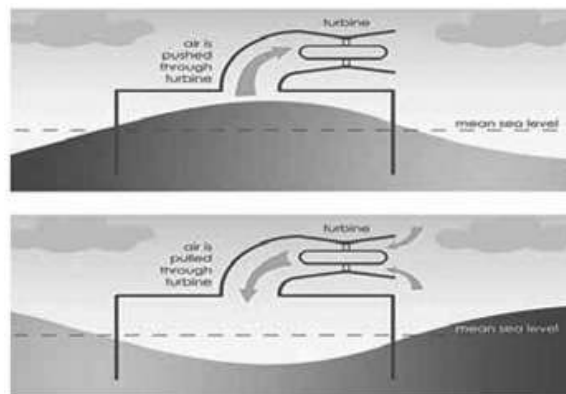

4.6 Tide characteristics and Statistics and Tide Energy Technologies

Tidal energy is a form of hydropower that converts the energy obtained from tides into useful forms of power, similar to electricity. Tides are created by the gravitational effect of the moon and the sun on the earth causing cyclical movement of the swell. One of the strengths of employing power from tidal ranges and tidal aqueducts over other forms of renewable energy is that the process is entirely predictable.

Characteristics of Tides

Following are the types and characteristics of tides

Flood Tide - Over a period of several hours there will be a rise in sea level.

High Tide - This is a stage where the water reaches its maximum level.

Ebb Tide - This is a stage where sea level keeps receding over several hours.

Low Tide - The Level of Seawater stops receding.

Tidal energy technologies

It can be subdivided into three categories

A. Tidal Range technology

Tidal range technologies harvest the potential energy created by the difference in head between ebb tide and flood tide. Such resources exist in locations where due to geological and ecological conditions, large water masses flow into compounded areas or bays and estuaries. Furthermore, tidal range energy is predictable, as the energy production is not influenced by weather conditions, but rather by the cyclical constellations, the gravity of the moon, sun, and earth, providing a predictable bi-week, biannual and annual cycle.

Tidal range technology has a number of options for power generation :

- I) One way power generation at ebb tide: The reservoir is filled at flood tide through sluice gates or valves that are closed once the tide has reached its highest level. At the ebb tide, the water in the reservoir is released through the turbines and power is generated. With this single cycle, power is generated for only four hours per day. Annapolis in Canada is an ebb generation plant.
- II) One way power generation at flood tide: At flood tide the sluice gates are kept closed to isolate the reservoir while at its lowest level. When the tide is high, the water from the sea-side flows into the reservoir via the turbines, thus generating power. The disadvantage of this cycle is that it has less capacity and generates less electricity, and it may be ecologically disadvantageous as the water level in the impoundment is kept at a low level for a long time.
- III) Two way power generation: Both incoming and outgoing tides generate power through the turbines. This cycle generates power for four hours twice daily. However, reversible turbines are required. Tidal current or tidal stream technologies convert the kinetic energy into useable energy.

B. Tidal Current Technologies

Tidal current or tidal stream technologies have made enormous strides in development towards commercialisation in the past five to seven years. Tidal current technologies can also be used to generate electricity from ocean currents.

C. Hybrid Forms

Hybrid forms of tidal energy can be found in the form of multi-purpose platforms where both tidal current and tidal range technologies are used for electricity generation. These platforms are in an early developmental and innovative stage

4.7 Ocean Thermal Energy, Osmotic Power, Ocean Biomass

Ocean Thermal Energy

The Earth oceans absorb solar radiation, the major part of which they store as thermal energy in the warm surface waters. On the other hand, cold water layers move slowly from polar regions towards the equator at depths of less than 1000 m. Thus, a vertical temperature difference amounting to up to 25°C exists throughout the year at many tropical and subtropical locations. According to the fundamental laws of thermodynamics, this temperature gradient can be exploited as an energy source. The warm surface waters and the cold water from depth, if brought into proximity, can be used as the heat source and heat sink, respectively, of a heat engine. Such a heat engine would operate in much the same fashion as a conventional power plant, except that no fuel would be required. The ocean-thermal gradient does not vary significantly from day to night and hence can be regarded as a quite steady source of energy. It does have, however, a seasonal variation which increases with the distance from the equator.

The natural power potential of the thermal gradient energy is estimated to be as large as 10¹³ W (10TW). Obviously it is not technically feasible to extract all this energy. Furthermore, what can be extracted in practice is even less than what is technically available. There exists today a wide range of figures given by experts as the practical power potential of ocean thermal energy. A fair estimation would be approximately 10ⁿW (0T TW). To better appreciate this figure it may be helpful to note that the world installed electrical generation capacity is of the order of 10¹² W (1 TW). This means that ocean thermal energy could make an important contribution to the world's electricity supply.

Osmotic Power

Osmotic power, salinity gradient power is the energy available from the difference in the salt concentration between seawater and river water. Two practical methods for this are reverse electrodialysis (RED) and pressure retarded osmosis (PRO). Both processes rely on osmosis with membranes. The key waste product is brackish water. This by product is the result of natural forces that are being harnessed: the flow of fresh water into seas that are made up of salt water.

Differing salinity gradient power generations exist but one of the most commonly discussed is pressure-retarded osmosis (PRO). Within PRO seawater is pumped into a pressure chamber where the pressure is lower than the difference between fresh and salt water pressure. Fresh water moves in a semipermeable membrane and increases its volume in the chamber. As the pressure in the

chamber is compensated a turbine spins to generate electricity. The pressure drives the turbines and power the generator that produces the electrical energy.

Ocean Bio-mass

Since solar energy is inexhaustible, regardless of its low conversion yield, vegetal biomass can be converted into energy without exhausting its supply. In the marine environment such biomass is present in large quantities as are the necessary nutrients for its elaboration; at upwelling sites, productivity is the highest. It is inconceivable to use large amounts of biomass to produce methane, for instance, since it would be environmentally unthinkable. Experiments for the mass production of algae that can adapt to a wide variety of light intensity have been conducted.

Marine biomass sources such as seaweeds and kelp have tremendous potential for production of fuels and high-value products. Their fast growth rates, ease of harvesting, and low preproduction cost make them suitable candidates for tapping the immense solar energy into useful energy and biobased products. Seaweeds are presently used as human foods, cosmetics, fertilizers, and for the extraction of industrial gums and chemicals (long- and short-chain) with medicinal and industrial uses. Selective separation of high-value products and fuels is a major challenge for any type of biomass. Thermochemical and biochemical conversion methods have been well tested for both terrestrial and marine biomass systems. Microwave methods and other ways of extraction have also been done recently for extracting proteins and high-value products from wet algae. In order to be sustainable, future technologies would focus on using most of the organics in the biomass and deriving a suite of high-value bio-based products and (/or) fuels. While a single method may not be attractive, a combination of technologies and their integration will be the way forward to using marine biomass.

4.8 Summary

Our earth has 70 percent of water. Energy is harvested from normal wave as well as tidal energy is also is harvested. The technology is refining to get maximum energy from the wave energy and tides.

4.9 Questions

1. What is ocean energy ?
2. How many methods are used for energy extraction from ocean? Give Brief description
3. What is wave energy device? Mention three popular device.
4. What is marine biomass ?

Unit 5 Geothermal Energy

5.1 Objective

To introduce about geothermal energy and its resource.

5.2 Introduction

The Geothermal energy is enormous and last for several millions of years. Hence it is called renewable energy. There is the large amount of heat lying in earth's interior in the form of Volcanoes, geysers and hot springs. This thermal energy contained in the interior of the earth is called geothermal energy.

Magma is the molten rock within the earth is pushed up towards the surface where the heat of the magma is being conducted upward through an overlying rock layer. The hot magma near the surface solidifies into igneous rock. The heat of the magma is conducted upward to this igneous rock. Ground water which finds its way down to this rock through cracks is heated by the heat of the rock or by mixing with hot gases and steam coming from magma. The heated water convectively rise upward and into a porous and permeable reservoir above the igneous rock.

5.3 Geothermal Resources

Hydrothermal source

- Vapour dominated or dry steam fields
- Liquid dominated system
- Hot-water fields

It contains superheated water, steam or both in fractures or porous rock but further trapped by a layer of impermeable rock. It may give dry and pure steam with the temperature above 240C. The majority of these resources have moderate temperature ranging from 100C to 180C while few resources have moderate temperature ranging from 150C to 200C.

Geopressured reservoirs

It is hot water trapped underground at the depth of about 4 km to 9 :1 km with temperature about 150C stored under pressure of about 1000 bar from the weight of overlying rock. It is used for heat and natural gas having great heat potential for power generation but uneconomical.

Hot dry rock or Petrothermal

It consist of high temperature rocks ranging from 90C to 650C. The rocks can be fractured and water may be circulated through the rocks to extract thermal energy.

Magma Resources

The molten rock or magma present in the volcanic vents at a temperature ranging from 700C to 1600C.

Volcanoes

5.4 Geothermal Technologies

Geothermal Power Plant

- Dry Steam Plants

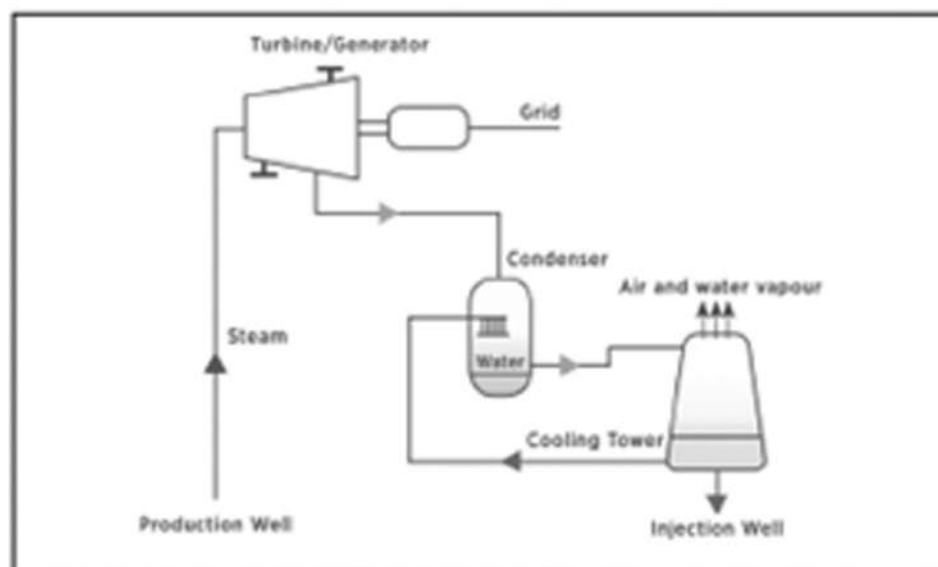

Source: IRENA, 2017c

Fig. 1 Dry Steam Plant

In this system the conversion device is the steam turbine which use directly the low pressure, high-volume fluid produced in the steam field. This plant commonly use condensing turbine and the condensate is re-injected in wet cooling towers. It uses steam of 150C. (Fig. 1).

● Flash Plant

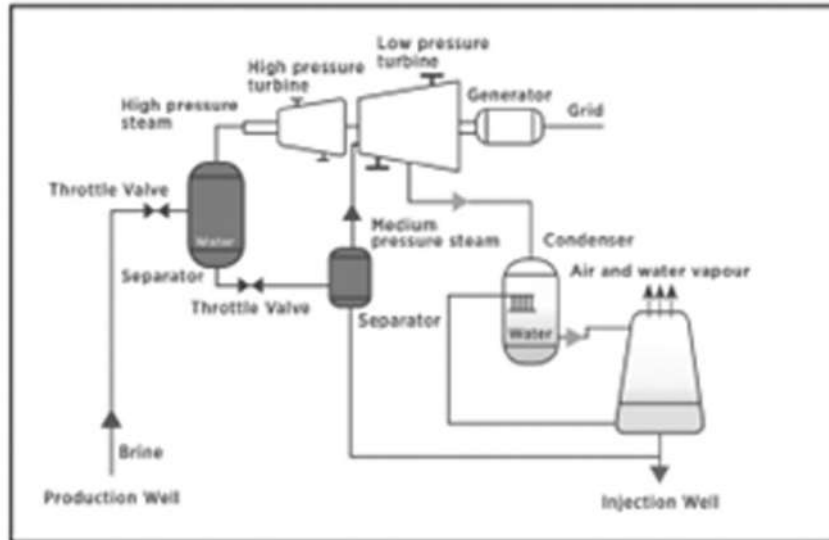

Source: IRENA, 2017c

Fig. 2 Flash Steam Plant

This power plant is similar to dry stream plant. The steam is obtained from separation process and then directed to the turbines after that the re-injection takes place at lower pressure. Flash plants vary in size depending on whether they are single, double or triple-flash. Fig. (2)

● Binary Plant

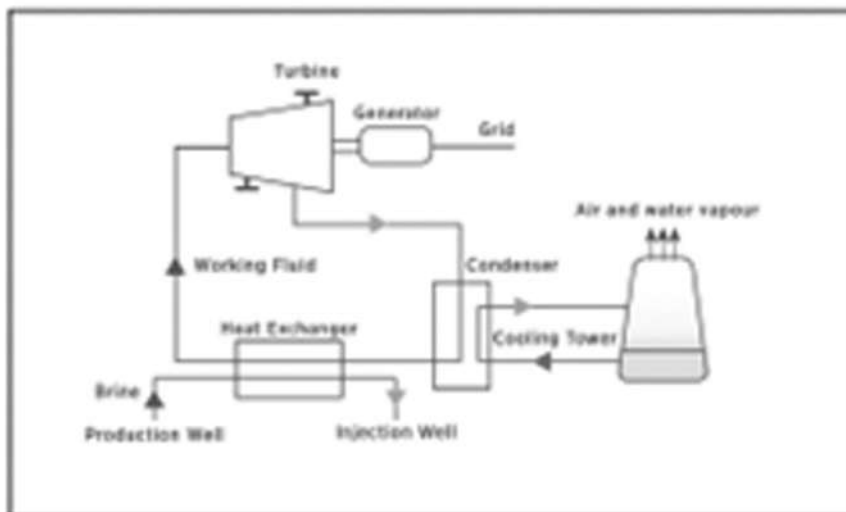

Source: IRENA, 2017c

Fig. 3 Binary Plant

It is basically a Rankine cycle with organic working fluid. To transfer a fraction of the brine enthalpy to vaporize the secondary working fluid. These plants

are usually applied to low or medium enthalpy geothermal fields where the resource fluid is used, via heat exchanger, to heat a process fluid in a closed loop having boiling and condensation points that match the geothermal resource temperature. Binary plants range in size from less than 1 MW to 50 MW. Fig. (3).

● **Combined Cycle or Hybrid Plant**

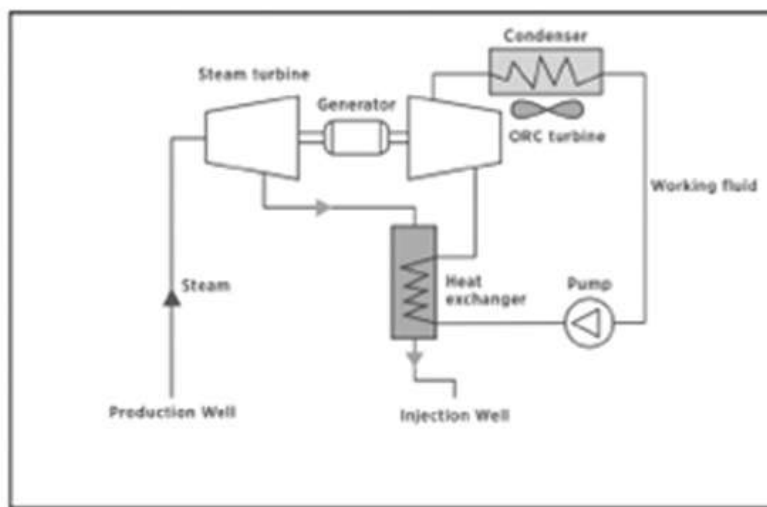

Adapted from: ORMAT, 2017

Fig. 4 Combined Cycle Plant

This type of power plants use combined cycle which adds a traditional Rankine cycle to produce electricity from which otherwise would become waste heat from a binary cycle. Using two cycle provides relatively high electric efficiency. Fig. (4). The same basics are used by the Hybrid geothermal power plant as a stand alone geothermal power plant but combine a different heat source into the process.

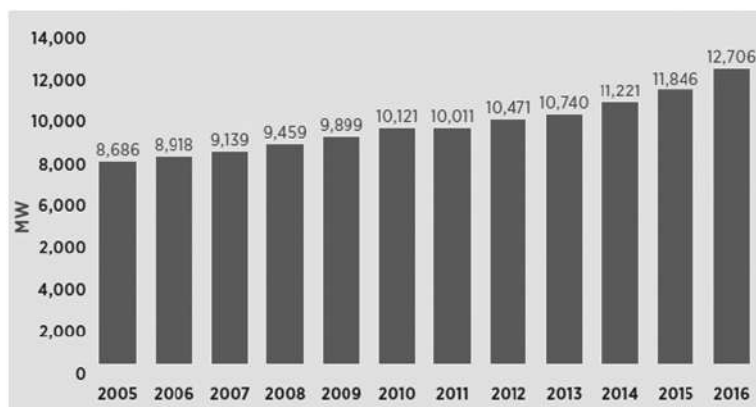

5.5 Summary

We know the core of the earth is very hot. It is possible to harvest this heat energy into electricity. The amount of energy harvested from geo thermal source is almost doubled in last 15 years.

5.6 Questions

1. What s Geo thermal energy?
2. How many types of plant are available to extract geo thermal energy?
3. Explain about combined cycle plant.

Unit 6 : Hydro Energy

6.1 Objective

6.2 Introduction

6.3 Hydropower resources

6.4 Hydropower technologies

6.5 Environmental impact of hydro power sources.

6.6 Summary

6.7 Questions

6.1 Objective

To introduce about hydropower resources of our planet.

6.2 Introduction

Hydropower (from the Greek word hydor, meaning water) is energy that comes from the force of moving water. The fall and movement of water is part of a continuous natural cycle called the water cycle.

Energy from the sun evaporates water in the Earth's oceans and rivers and draws it upward as water vapor. When the water vapor reaches the cooler air in the atmosphere, it condenses and forms clouds. The moisture eventually falls to the Earth as rain or snow, replenishing the water in the oceans and rivers. Gravity drives the moving water, transporting it from high ground to low ground. The force of moving water can be extremely powerful.

Hydropower is called a renewable energy source because the water on Earth is continuously replenished by precipitation. As long as the water cycle continues, we won't run out of this energy source.

6.3 Hydropower resources

Hydro Dams

It is easier to build a hydropower plant where there is a natural waterfall. That's why both the U.S. and Canada have hydropower plants at Niagara Falls. Dams, which create artificial waterfalls, are the next best way.

Dams are built on rivers where the terrain will produce an artificial lake or reservoir above the dam. Today there are about 87, 000 dams in the United States,

but less than three percent (2, 200) were built specifically for electricity generation. Most dams were built for recreation, flood control, fire protection, and irrigation.

A dam serves two purposes at a hydropower plant. First, a dam increases the head, or height, of the water. Second, it controls the flow of water. Dams release water when it is needed for electricity production. Special gates called spillway gates release excess water from the reservoir during heavy rainfalls.

6.4 Hydropower technologies

Hydropower plants

A people discovered centuries ago, the flow of water represents a huge supply of kinetic energy that can be put to work. Water wheels are useful for generating motion energy to grind grain or saw wood, but they are not practical for generating electricity. Water wheels are too bulky and slow.

Hydroelectric power plants are different. They use modern turbine generators to produce electricity, just as thermal (coal, natural gas, nuclear) power plants do except they do not produce heat to spin the turbines.

How a Hydropower Plant Works

A typical hydropower plant is a system with three parts :

- a power plant where the electricity is produced;
- a dam that can be opened or closed to control water flow; and
- a reservoir (artificial lake) where water can be stored.

To generate electricity, a dam opens its gates to allow water from the reservoir above to flow down through large tubes called **penstocks**. At the bottom of the penstocks, the fast-moving water spins the blades of turbines. The turbines are connected to generators to produce electricity. The electricity is then transported via huge transmission lines to a local utility company.

Tidal Energy

The tides rise and fall in eternal cycles. The waters of the oceans are in constant motion. We can use some of the ocean's energy, but most of it is out of reach. The problem isn't harnessing the energy as much as transporting it. Generating electricity in the middle of the ocean just doesn't make sense-there's no one there to use it. We can only use the energy near shore, where people need it.

Tidal energy is the most promising source of ocean energy for today and the near future. Tides are changes in the level of the oceans caused by the rotation of the Earth and the gravitational pull of the moon and sun. Near shore water levels

can vary up to 40 feet, depending on the season and local factors. Only about 20 locations have good inlets and a large enough tidal range-about 10 feet-to produce energy economically.

Tidal energy plants capture the energy in the changing tides. A low dam, called a barrage, is built across an inlet. The barrage has one-way gates called sluices that allow the incoming flood tide to pass into the inlet. When the tide turns, the water flows out of the inlet through huge turbines built into the barrage, producing electricity. The oldest and largest tidal plant- La Rance in France-has been successfully producing electricity since 1966.

Tidal plants have very high development costs. It is very expensive and takes a long time to build the barrages, which can be several miles long. Also, tidal plants produce electricity less than half of the time. The seasons and cycles of the moon affect the level-and the energy-of the tides. The tides are very predictable, but not controllable.

On the other hand, the fuel is free and non-polluting, and the plants have very low operating costs. The plants should run for a hundred years with regularly scheduled maintenance.

Tidal power is a renewable energy source. Though they produce no air pollution, the plants do affect the environment. During construction, there are major short-term changes to the ecology of the inlet. Once the plants go into operation, there can be long-term changes to water levels and currents. The plants in operation have reported no major environmental problems.

Wave Energy

There is also tremendous energy in waves. Waves are caused by the wind blowing over the surface of the ocean. In many areas of the world, the wind blows with enough consistency and force to provide continuous waves. The west coasts of the United States and Europe and the coasts of Australia and southern Africa are good sites for harnessing wave energy.

There are several ways to harness wave energy. The motion of the waves can be used to push and pull air through a pipe. The air spins a turbine in the pipe, producing electricity.

Another way to produce energy is to bend or focus the waves into a narrow channel, increasing their power and size. The waves can then be channeled into a catch basin, like tidal plants, or used directly to spin turbines.

Other ways to produce electricity using wave energy are currently under development. Some devices are anchored to the ocean floor while others float on top of the waves.

OTEC

The energy from the sun heats the surface water of the ocean. In tropical regions, the surface water can be much warmer than the deep water. This difference can be used to produce electricity. Ocean Thermal Energy Conversion, or OTEC, has the potential to produce more energy than tidal, wave, and wind energy combined, but it is a technology for the future.

The warm surface water is turned into steam under pressure, or used to heat another fluid into a vapor. This steam or vapor spins a turbine to produce electricity. Pumps bring cold deep water to the surface through huge pipes. The cold water cools the steam or vapor, turning it back into liquid form, and the closed cycle begins again. In an open system design, the steam is turned into fresh, potable water, and new surface water is added to the system.

6.5 Environmental impact of hydro power sources

Hydropower dams can cause several environmental problems, even though they burn no fuel. Damming rivers may permanently alter river systems and wildlife habitats. Fish, for one, may no longer be able to swim upstream.

Hydro plant operations may also affect water quality by churning up dissolved metals that may have been deposited by industry long ago. Hydropower operations may increase silting, change water temperatures, and change the levels of dissolved oxygen.

Some of these problems can be managed by constructing fish ladders, dredging the silt, and carefully regulating plant operations.

6.6 Summary

Other than wave energy and tidal energy scientists are working to harvest ocean thermal energy conversion process. The surface water of ocean is much hotter than water under few hundreds meter of the ocean. This temperature difference is used to harvest energy.

6.7 Questions

1. What is hydropower energy ?
2. What is hydro power resources ?
3. What is tidal energy ?
4. What is OTEC ?

Unit 7 : Piezoelectric Energy harvesting

Contents

- 7.1 Objective**
- 7.2 Introduction**
- 7.3 Physics and characteristics of piezoelectric effect, materials and mathematical description of piezoelectricity**
- 7.4 Piezoelectric parameters and modeling piezoelectric generators**
- 7.5 Piezoelectric energy harvesting applications, Human power**
- 7.6 Summary**
- 7.7 Questions**

7.1 Objective

To understand the piezoelectricity and its possibility of harvesting energy from this property of material.

7.2 Introduction

The piezoelectric effect converts mechanical strain into electrical voltage. This strain can come from many different sources. Human motion, low-frequency seismic vibrations and acoustic noise are a few examples. The piezoelectric effect can be implemented to harvest mechanical energy from walking. This energy can be converted into useful electrical energy that can be used to power wearable electronic devices such as sensors and Global Positioning System (GPS) receivers. Piezoelectric energy harvesting can also be used to power some consumer electronic devices directly such as cellular phones, two-way communicators and pagers.

Piezoelectricity is the ability of some crystals to generate an electric potential in response to an applied mechanical stress. When the crystal is under mechanical stress (e.g. by compression or expansion), the electrical charge of the dipoles become aligned, leading to a net electric polarization. This is responsible for the electric potential across the crystal and provides a convenient transducer effect between electrical and mechanical oscillations. If mechanical vibrations are applied to such crystals, they will respond with an electrical oscillation output which can act as a source of power. These effects can be exploited to harvest energy from disturbance sources. For the electrical power to be useful, an additional electronic

circuit would be required to rectify and regulate the power output in the most efficient way possible.

7.3 Physics and characteristics of piezoelectric effect, materials, and mathematical description of piezoelectricity

Piezoelectricity was discovered by two French scientists' brothers, Jacques and Pierre Curie, in 1880. They found out about piezoelectricity after first realizing that pressure applied to quartz or even some certain crystals creates an electrical charge in that certain material. They later referred to that strange and scientific phenomenon as the piezoelectric effect.

The Curie brothers soon discovered the inverse piezoelectric effect. It was after they verified that when an electric field was enforced onto crystal leads, it led to the malformation or disorder to the crystal lead-now called the inverse piezoelectric effect.

The term piezoelectricity comes from the Greek word piezo meaning to squeeze or press. Interestingly, electric in Greek means amber. Amber also happened to be a source of electrical charge.

As stated, compressing a piezoelectric material produces electricity (piezoelectricity). Figure 7.3.1 explains the concept.

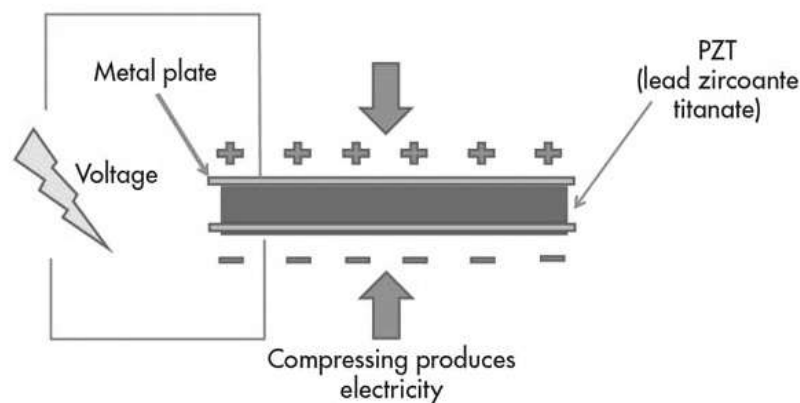

Fig. 7.3.1 Schematic diagram of piezoelectric effect.

The piezoelectric effect occurs through compression of a piezoelectric material.

Piezoceramic material-non-conductive piezoelectric ceramic or crystal-is placed between the two metal plates. For piezoelectricity to be generated, it needs that material to be compressed or squeezed. Mechanical stress applied to piezoelectric ceramic material generates electricity.

As shown in Fig. 7.3.1, there's a voltage potential across the material. The two metal plates sandwich the piezo crystal. The metal plates collect the charges, which creates/produces voltage (lightning bolt symbol), i.e., piezoelectricity. In this way, the piezoelectric effect acts like a miniature battery, because it produces electricity. This is the direct piezoelectric effect. Devices that use the direct piezoelectric effect include microphones, pressure sensors, hydrophones, and many other sensing types of devices.

Piezoelectric Materials

There are many materials, both natural and man-made, that exhibit a range of piezoelectric effects. Some naturally piezoelectric occurring materials include Berlinite (structurally identical to quartz), cane sugar, quartz, Rochelle salt, topaz, tourmaline, and bone (dry bone exhibits some piezoelectric properties due to the apatite crystals, and the piezoelectric effect is generally thought to act as a biological force sensor). An example of man-made piezoelectric materials includes barium titanate and lead zirconate titanate.

In recent years, due to the growing environmental concern regarding toxicity in lead-containing devices and nowadays there has been a push to develop lead free piezoelectric materials. To date, this initiative to develop new lead-free piezoelectric materials has resulted in a variety of new piezoelectric materials which are more environmentally safe.

7.4 Piezoelectric parameters and modeling piezoelectric generators

Piezoelectric Parameters :

Piezoelectric Charge (Strain) Constant

The piezoelectric charge coefficient relates the electric charge generated per unit area with an applied mechanical force and is expressed in the unit of Coulomb/Newton (C/N). This constant is most frequently used to evaluate the goodness of a piezoelectric material.

$$d = \frac{\text{Strain developed}}{\text{Applied field}} = \frac{\text{Charge density (open circuit)}}{\text{Applied stress}}$$

The d constant is associated with three important materials properties through the following the equation

$$d = k\sqrt{\epsilon_0 k^T S^E}$$

where k is electro-mechanical coupling coefficient, kT denotes relative dielectric

constant at a constant stress, and s_E is elastic compliance (10 m/N) at a constant electrical field. There are two important d constants :

$$d_{31} = k_{31} \sqrt{\epsilon_0 k_3^T S_{11}^E}$$

$$d_{33} = k_{33} \sqrt{\epsilon_0 k_3^T S_{33}^E}$$

It is useful to remember that large d constants relate to large mechanical displacements, which are usually sought in motional transducer devices. Conversely, the coefficient may be viewed as relating the charge collected on the electrodes, to the applied mechanical stress. d_{33} applies when the force is along the three direction (parallel with the polarization axis) and is impressed on the same surface from which the charge is collected. d_{31} applies when the charge is collected from the same surface as with d_{33} , but the force is applied at right angles to the polarization axis. It is commonly known that they have the following empirical relation.

$$d_{33} \approx -2.5 \cdot d_{31}$$

Piezoelectric Voltage Coefficient (G-constant)

The piezoelectric voltage coefficient is also called voltage output constant, which is defined as the ratio of the electric field produced to the mechanical stress applied and is expressed in the unit of voltage-meter/Newton (Vm/N).

$$g = \frac{\text{Strain developed}}{\text{Applied charge density}} = \frac{\text{Field developed}}{\text{Applied mechanical stress}}$$

The g -constants are calculated from the piezoelectric charge (strain) constant (d) and relative permittivity (ϵ) from the equation

$$g = \frac{d}{\epsilon}$$

Depending on the type of relative directions, the g constant can be categorized as g_{33} , g_{31} , or g_{15} , corresponding to d_{33} , d_{31} , or d_{15} , respectively.

Piezoelectric Coupling Coefficient

The piezoelectric coupling coefficient (sometimes referred as the electromechanical coupling coefficient) is defined as the ratio of the mechanical energy accumulated in response to an electrical input or vice versa. It also corresponds to the fraction of electrical energy that can be converted into mechanical energy and vice versa. Thus, the piezoelectric coupling coefficient can be expressed by the following equation :

$$x = \sqrt{\frac{\text{Mechanical energy stored}}{\text{Electrical energy applied}}} = \sqrt{\frac{\text{Electrical energy stored}}{\text{Mechanical energy applied}}}$$

The coupling factor can be calculated based on the measured resonance and anti-resonance frequencies of a piezoelectric element, depending on the vibration mode at which the element is excited. The most used coupling factors are k_p and k_t for the vibration along the radial and thickness directions in a circle-shaped disk, respectively. In general, a useful parameter k_{eff} is frequently used to express the effective coupling coefficient of an resonator with an arbitrary shape, either at its fundamental resonance or at any overtone modes, and is expressed as follows

$$k_{eff}^2 = 1 - \left(\frac{f_r}{f_a} \right)^2$$

where f_r and f_a stand for resonating frequency and anti-resonating frequency, respectively. The coupling coefficients can be calculated for the various modes of vibration from the following equations

$$\frac{k_p^2}{1 - k_p^2} = \frac{(1 - \sigma^K) J_1 \left[\eta_1 \left(1 + \frac{\Delta F}{F_r} \right) \right] - \eta_2 \left(1 + \frac{\Delta F}{F_r} \right) J_0 \left[\eta_1 \left(1 + \frac{\Delta F}{F_r} \right) \right]}{(1 + \sigma^E) J_1 \left[\eta_1 \left(1 + \frac{\Delta F}{F_r} \right) \right]}$$

where,

J = Bessel function of the first kind and zero order

J_1 = Bessel function of the first kind and first order

σ^E = Poisson's ratio

η_1 = Lowest positive root of $(1 + \sigma^E) J_1 \eta = \eta J_0(\eta)$

F_r = Resonance frequency (Hz)

F_a = Anti-resonance frequency (Hz)

$\Delta F = F_a - F_r$ (Hz)

Assuming that $\sigma^E = 0.31$ for PZT ceramics and $\eta_1 = 2.05$, the following simplified equation holds :

$$k_{33}^2 = \frac{\frac{x}{2}}{1 + \frac{\Delta F}{F_r}} \tan \frac{\frac{x}{2} \frac{\Delta F}{F_r}}{1 + \frac{\Delta F}{F_r}} \quad \text{and} \quad k_{33}^2 = \frac{\frac{x}{2}}{1 + \frac{\Delta F}{F_r}} \tan \frac{\frac{x}{2} \frac{\Delta F}{F_r}}{1 + \frac{\Delta F}{F_r}}$$

Mechanical Quality Factor

The mechanical Qm is the ratio of the reactance to the resistance in the series equivalent circuit representing the piezoelectric resonator, which is related to the sharpness of the resonance frequency. The mechanical Qm can be calculated using the equation :

$$Q_m = \frac{f_r}{f_2 - f_1}$$

where f_r is the resonance frequency, f_1 and f_2 are frequencies at -3 dB of the maximum admittance. The mechanical Q_m is also related to the electromechanical coupling factor k , following the equation :

$$Q_m = \frac{1}{2rF_r Z_m C_0} \left(\frac{F_a^2}{F_a^2 F_r^2} \right)$$

where, F_r = Resonance frequency (Hz)

F_a = Anti-resonance frequency (Hz)

Z_m = Impedance at F_r (ohm)

C_0 = Static capacitance (Farad)

Modelling piezoelectric generators :

Piezoelectric generators are usually specified in terms of their short-circuit charge and open-circuit voltage. Short-circuit charge, Q_s , refers to the total charge developed, at the maximum recommended stress level, when the charge is completely free to travel from one electrode to the other, and is not asked to build

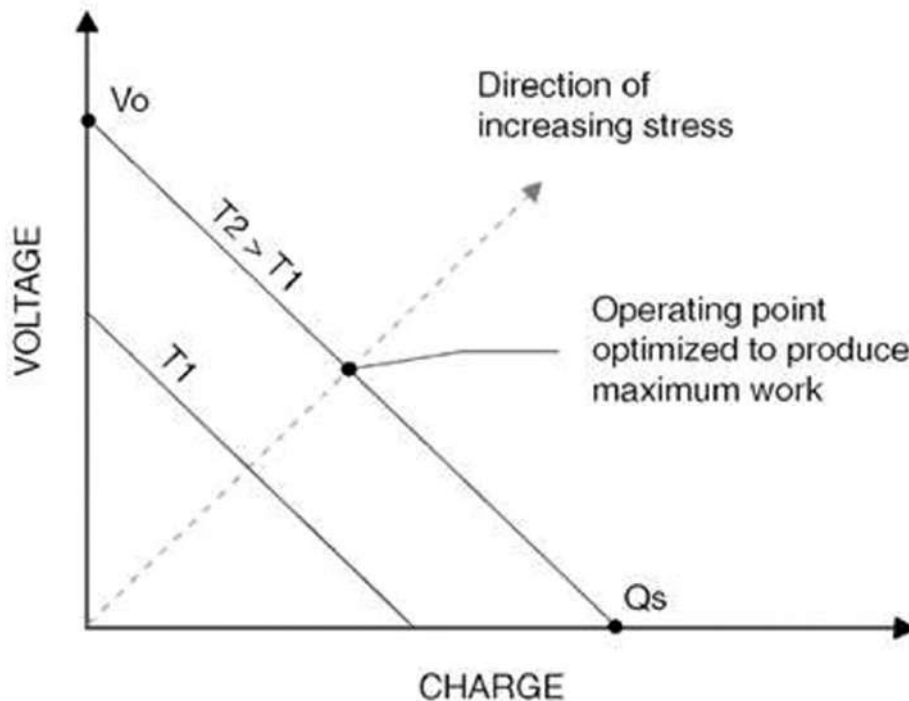

Fig 7.4.1: The voltage versus charge diagram for a piezoelectric generator element

up any voltage. Open-circuit voltage, V_o , refers to the voltage developed, at the maximum recommended stress level, when charge is prohibited from traveling from one electrode to the other. Charge is at a maximum when the voltage is zero, and voltage is at a maximum when the charge transfer is zero. All other values of simultaneous charge and voltage levels are determined by a line drawn between these points on a voltage versus charge line, as shown in Figure 13. Generally, a piezo generator must move a specified amount of charge and supply a specified voltage, which determines its operating point on the voltage vs. charge line. Work is maximized when the charge moved permits one half the open circuit voltage to be developed. This occurs when the charge equals one half the short-circuit charge.

MECHANICAL INPUTS

Mechanical inputs can be described as either forces or displacements acting on a specific point or area of the generator body. These forces may be either static or dynamic, low power (typically sensing) or high power (typically generating). If the force is oscillating and continuous, then the generator may be driven either at resonance or off- resonance (typically below resonance)

STATIC INPUT FORCES OR DISPLACEMENTS

For long duration static forces acting on a piezo generator, such as a static pressure measurement, an understanding of creep, hysteresis and electrical leakage is useful.

Creep & Relaxation : Creep and relaxation are time dependent plastic phenomena resulting from piezoceramic grains slipping within the polycrystalline material upon application or removal of a load. When a constant load is applied and maintained on a piezo body, it will initially deform and then continue to deform (creep) over a period of time. There are three levels of creep: transient creep occurring immediately after load application; steady state creep characterized by a decreasing creep rate; and accelerating creep. At high drive levels, accelerated creep may proceed to the point where the piece finally cracks. Creep rates vary based on load level, temperature, and time. Upon removal of the load, the piece may slowly relax to its original equilibrium condition or retain a set.

Mechanical Hysteresis : Hysteresis is a lagging of strain values during stress cycling. When a polycrystalline piezoelectric body is deformed, part of the input energy is stored as elastic strain energy, and part is dissipated as heat due to small internal slippage mechanisms. Hysteresis appears as an offset in the strain level between the application and removal portions of a stress load. The size of the offset depends on the force level, cycle time, temperature, and materials used. For low stress levels encountered in small signal sensing, hysteresis is inconsequential, but

for moderate and high stress levels it may be significant. Hysteresis is described as a percentage of the total strain and ranges around 15% for high stress levels. Voltage or charge production, which is strain dependent, is influenced by the mechanical hysteresis behavior. Hysteresis leads to non-linearity in transducer output.

Figure 7.4.2 demonstrates the typical mechanical hysteresis and creep behavior of a piezoelectric element such as a bender. Imagine a force applied to the tip of a cantilevered bending element. When the element has been at rest for some length of time (~1 day), it will reside at its equilibrium position, 0. Upon initial energization, the tip will move to position 1. After de-energization it will go to position 2. If it is allowed to rest for a sufficient length of time (~1 day) it will revert back to position 0 again. However, if it is forced again immediately, it will follow path 2-1. If the force is left on, it will creep along the path 1-1', and come to rest at position 2' after de-energization. A piece experiencing a full bipolar cycle will follow path 1-2-3-4-1. The size of the loop is time dependent and the area inside the loop represents the energy dissipation occurring during the cycle.

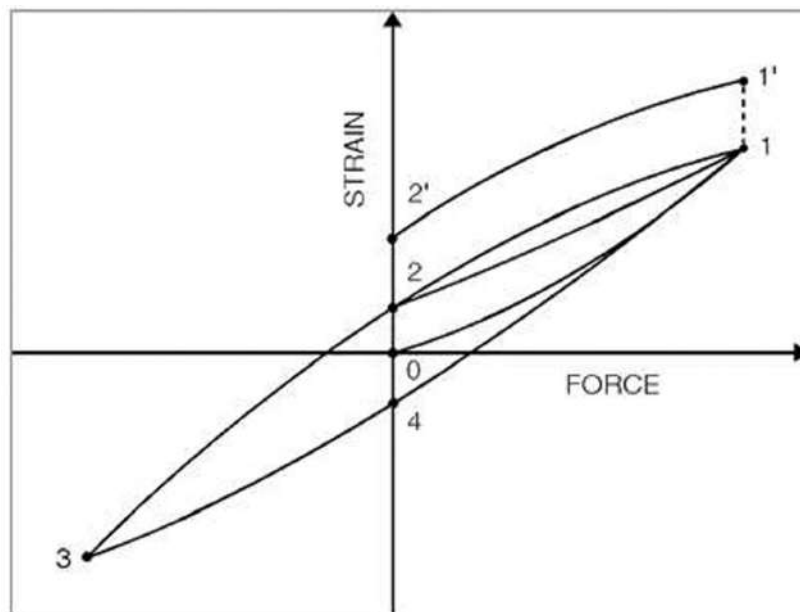

Fig: 7.4.2 force vs strain of a piezoelectric material.

Electrical Leakage: After charge has been established on the electrodes of a piezo generator, it will immediately begin to leak away even though the insulation resistance is large. It will leak through the bulk of the piezo slab according to the relation for bulk resistance

$$R = \frac{\rho t}{A}$$

where ρ is the bulk resistivity of the piezo material in ohm-meters, t is the

thickness between electrodes, and A is the electrode area. The value of resistivity for PZT-5A is $\sim 10^{10}$ ohm-meters. Charge will travel along surfaces and over edges from one electrode to the other. Surface contaminants exacerbate this problem. Charge also drains through the input circuit. Lastly, charge may drain through the bleed resistor often placed across the electrodes to limit voltage swings due to pyroelectric (thermal) sources, triboelectric (surface friction) sources, and transient circuit currents. Eventually, the electrostatic charge will leak back to zero.

Overall, the behaviour described above indicates why it is so difficult to design statically driven piezo sensing devices and why only dynamic force is generally measured.

DYNAMIC INPUT FORCES OR DISPLACEMENTS

Piezo is much more friendly to dynamic applications. Dynamic inputs may either be pulsed or continuous.

Pulsed Input Forces: For a short duration transient force, issues of creep and electrical leakage are insignificant since there is insufficient time for their behavior to occur. However, hysteresis still applies.

Continuously Alternating Input Forces : When the generator will be excited by an oscillating force, it is useful to be familiar with the following concepts:

Hysteresis : Hysteresis is a concern with oscillating forces because heat accumulates within the element for each cycle of operation. Heat accumulates from contributions due to mechanical losses described earlier and dielectric losses attributed to the phase lag between charge displacement and electric field. Low voltage piezo stacks are generally limited to < 1 kHz operation at full loading due to heat buildup. Care should be taken in the design to account for heating caused by internal piezo losses as well as external system losses, such as strains within adhesive bonds, and friction at the mount or other points of attachment.

Mechanical Resonance : When a piezo body is acted upon by a periodic series of impulses, it will be set into relatively large amplitude vibration if the frequency of those impulses corresponds to the natural or resonant frequency of the device. This resonance is a manifestation of the trading back and forth of kinetic energy (moving mass) and potential energy (elasticity) in the oscillating body. At resonance, the amount of stored energy becomes very large compared to the excitation energy. For this reason, it is useful for achieving large voltages at low stress levels, and thus, for obtaining high efficiency. Because of the high amplitudes exhibited, care must be taken not to overstrain and crack the generator.

The resonant frequencies of a piezo generator depend on its dimensions, material properties, and the manner of mounting. The cantilevered piezo bending

element, being very compliant, has the lowest fundamental resonant frequency per unit length of all configurations and mounting schemes. The piezo stack, being very stiff, has a high resonant frequency. Equations for determining the fundamental resonant frequencies for several generator configurations are shown in Table 4 on pages 38 and 39. These frequencies apply to unloaded elements only. Attachments to the element will add to the resonating mass and lower the resonant frequency.

Operating Frequency Band : Below resonant frequency, the strain of a piezoelectric transducer is nearly independent of frequency and proportional to the applied stress. Around the resonant frequency, strain rises rapidly to a multiple of its normal value. The amplitude and narrowness of the resonance depend on the internal and external losses acting on the generator. Above resonance, strain decreases steadily with the square of the frequency. Generally, for quasi-static transducers, a value of about 2/3 of the fundamental resonance marks the limit of the usable frequency band. For resonant applications, the useable frequency range is limited to a small band around the useful resonant modes.

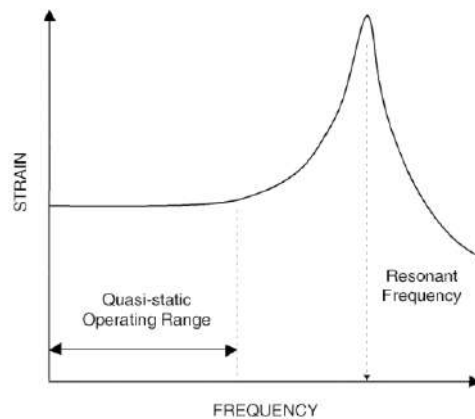

Figure 7.4.3 strain as a function of operating frequency.

MECHANICAL CONSIDERATIONS

MECHANICAL RESPONSE TIME

It is useful to know how fast a generator element can respond to a force input. The fundamental resonant frequency, f_r , helps answer this question. A piezo transducer can follow a sinusoidal input up to its resonant frequency. Beyond this point, inertia prevents the transducer from keeping up with excitation. The time it takes a generator to travel from its zero position to full positive amplitude at its resonant frequency, is its response time, t_r . This is 1/4 the time it takes the transducer to travel a full bipolar cycle (from zero to peak positive amplitude to 0 to peak negative amplitude back to zero). Thus,

$$t_r \sim \frac{1}{4F_r}$$

The response time of a generator may be measured by driving it as an actuator with a low-level sinusoidal signal at resonance. For example, a generator having a resonant frequency of 500 Hertz, has a response time of 0.5 milliseconds under ideal conditions. In a practical setting, this response time is rarely achieved due to hysteresis and other losses. Any mass added to the end of the generator will increase the response time.

$$t_r \sim \frac{1}{3F_r}$$

MOUNTING

An ideal mount permits the normal distortion of the entire active portion of the generator element, while at the same time preventing motion in certain directions at the mounting point or points. Generally, piezo generators are either bonded, clamped, or spring loaded to their mounting points. Mounts introduce some mechanical damping into the system since some of the energy from the generator distorts the mount itself. This may or may not be desirable.

STRENGTH LIMITATIONS

Piezoceramic is very strong in compression but weak in tension. Bending elements always have one side in compression and the other side in tension, where the magnitude of stress increases linearly from the midplane to the outside surface. Therefore, the element is always limited by the maximum recommended tensile strength, generally considered to be in the range of $20\text{-}35 \times 10^6$. Newtons/meter². From a strain point of view, the piezoceramic should not be allowed to strain more than

500×10^{-6} meter/meter in tension.

STRESS DEPOLING

When the mechanical stress on a piezoceramic element becomes too high, again there is a danger of degrading the piezoelectric properties. Generally, compressive or hydrostatic stress levels of $\sim 50 \times 10^6$ N/m² are required to degrade PZT-5A if no other degrading influences are present.

ELECTRICAL CONSIDERATIONS

QUASI-STATIC OPERATION

A piezoelectric generator operating below its fundamental resonance can be treated simply as a capacitive element. It supplies, withdraws or stores charge. Ideally, this charge does not leak away. However, in practice charge may leak through the bulk material, over its edges, or through external circuitry.

NEAR RESONANCE OPERATION

A piezoelectric generator operating at resonance can be treated as a capacitor (having a value equal to the transducer capacitance) with a resistor in parallel. The power dissipated by this resistance represents the work which the transducer does on its environment or the internal loss occurring within the transducer.

ELECTRICAL ISOLATION

The outer electrode surfaces of certain generator elements are electrically “live” in many configurations. For product or experimental safety, consideration should be given to insulating or shielding the electrodes, mount, and power input sections of the generator element.

ELECTRICAL BREAKDOWN

The highest value of generated electric field is determined by electrical breakdown occurring either through the body of the piezoceramic sheet or over the its edges. Debris adhering to edges can initialize edge discharge at fields as low as 400-800 volts/mm. Continuous breakdown occurs around 3,000-4,000 volts/mm, usually at impurity or defect regions within the bulk of the material. This can lead to a short circuit across the sheet.

ELECTRICAL LOSSES

The bulk resistivity of piezoceramic is $\sim 10^{12} \Omega\text{-cm}$. Therefore, electrical losses are minimal under static or low frequency operation. However, dielectric losses are significant at high frequency, under high load, and can lead to heating under high frequency /high power operation. The loss tangent, the ratio of series resistance to series reactance, for PZT-5A is ~ 0.015 .

ELECTRICAL DEPOLARIZATION

As mentioned earlier, under adverse conditions piezoelectric polarization may degrade, vanish completely, or be flipped around 180° . A strong electric field applied to a piezoceramic in a sense opposite to the original poling voltage will tend to cause depoling. The field strength necessary to initiate depoling depends on the material, duration of application, and temperature, but is typically in the range of 475 volts/mm at 20°C for PZT-5A under static conditions. Alternating fields may also degrade the piezoceramic, but the peak field level is higher because the duration is shorter before the field is reversed. A peak field of 600 volts/mm may be tolerated for 60 Hz operation at 20°C .

PIEZO CHARGE GENERATOR

Figure 7.4.3 shows the equivalent circuit for a piezo charge generator. The only thing in this circuit that is accessible to the outside world is the two-terminal

output interface. The value of C_p is the lab measured piezo capacitance and R_p is the measured internal DC resistance of the piezo device. Since the bulk resistivity of piezoceramic is of the order of $\sim 10^{12} \Omega\text{-cm}$, R_c routinely runs in the giga Ohms and so is generally neglected. Q represents the charge generated by time dependent stresses exerted on the piezoceramic and can be calculated based on the design of the part, its mechanical mounting, and applied external forces.

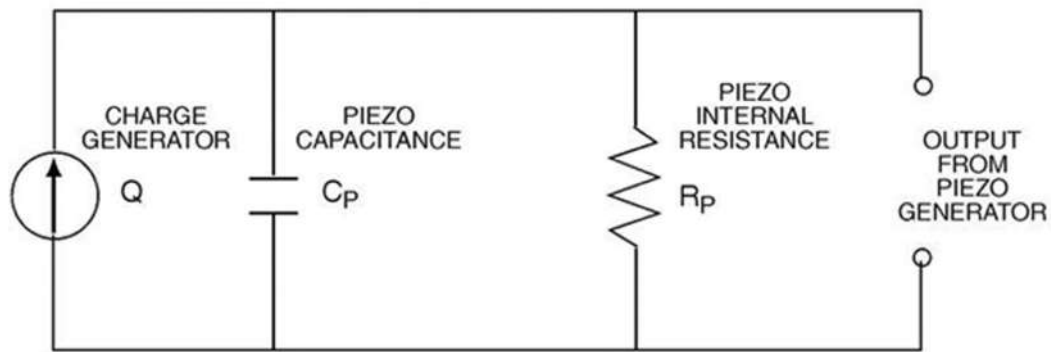
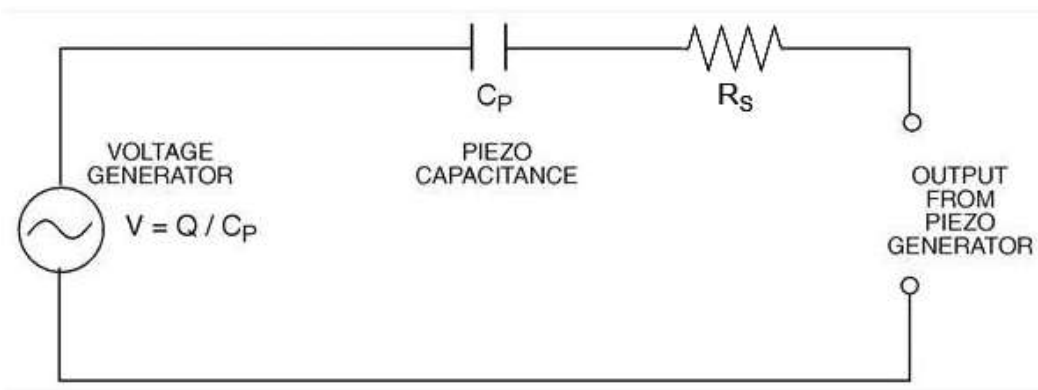

Figure 7.4.3 Piezo transducer modelled as a charge generator.

PIEZO VOLTAGE GENERATOR

Since voltage can be calculated from the charge delivered by a piezo device according to the relationship that $V = Q / C_p$, Figure 7.4.5 shows a piezo device modeled as a voltage generator. Voltage output V is the open circuit voltage, and proportional to the stress applied to the piezo device C_p is the lab measured capacitance of the piezo sensor. R_s , the equivalent series resistance of the sensor, is frequently taken as zero. Unlike the R_p of the Charge Generator model however, R_s is not entirely internal to the sensor. Both surface resistance of the piezoceramic electrodes (typically sub-Ohm to 10 Ohms), solder connections, cable resistance, and connector contact resistance can contribute R_s .



7.5 Piezoelectric energy harvesting applications, Human power

Piezoelectric harvesters consist of an active dielectric material, the piezoelectric, which is plated with a conductor or has an arrangement of a conductor to capture the electric charge developed due to mechanical displacement. PEH devices use vibrations, motion or acoustic noise as the source of external energy which can be converted to electrical energy. These are typically used for application with low power requirements such as powering sensor equipment from ambient vibrations, MEMS application, wireless sensor, and military applications. Although significant progress has been made in this field in the development of microscale power supplies, power management and consumption, there remains a need to improve these further with the advent of the Internet of Things (IoT). A piezoelectric material can produce an electric charge when the material undergoes mechanical stress. There are many materials such as quartz and tourmaline crystals that exhibit this piezoelectric effect. Such materials have in the past been actively used as electromechanical transducers. The ferroelectric group of materials which exhibit the piezoelectric effect are also known as piezoelectric materials. Ferroelectric ceramics such as lead zirconate titanate (PZT) are widely used in Energy harvesting due to their favourable properties and much discussion can be found in the literature on these. PZT harvesters have been considered to be a prospective replacement for batteries in some applications due to their high piezoelectric character and energy output. Polymers such as polyvinylidene fluoride (PVDF) are mainly used in applications requiring a higher degree of mechanical flexibility and optical transparency. These polymers are relatively cheap and can be easily integrated into various applications; in garments or shoes. These polymers also exhibit unique features such as demonstrating excellent mechanical behaviour, being corrosion resistant, having the ability to withstand stress without structural fatigue and illustrating ease of processability on dielectric thin films. In particular, these polymers have the potential to be integrated into flexible devices. A model single degree-of-freedom of a piezoelectric vibration energy harvester presented in Figure 7.5.1. A mass is connected by means of a spring where k is the elastic modulus (stiffness of the spring), \ddot{y} is the acceleration applied to the base, x is the displacement of mass. Vibrations cause a movement of the magnet which in turn applies force on the piezoelectric element due to the oscillating movement.

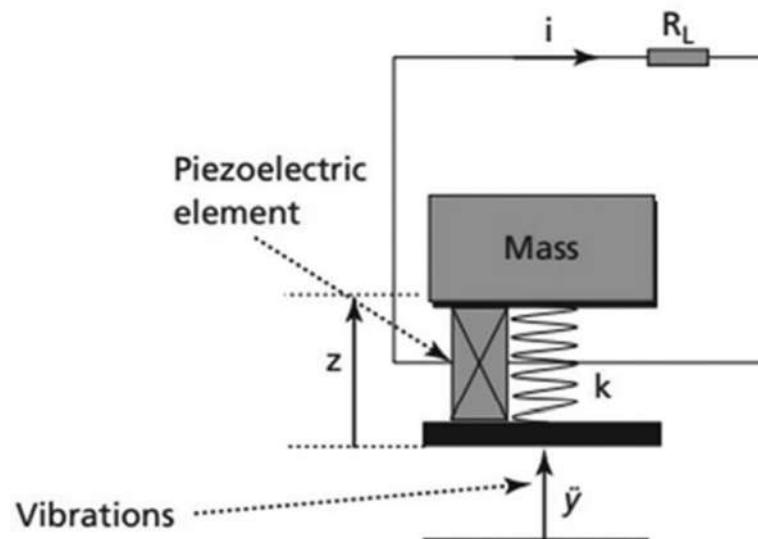

Fig 7.5.1 Model of a single degree-of-freedom piezoelectric vibration energy harvester.

7.6 Summary

One of the most modern approach to get energy is the phenomenon of piezo electricity. The small devices already developed the get electrical energy from mechanical energy.

7.7 Questions

1. What is piezo electric effect?
2. What is piezo electric power harvesting?
3. Give few examples of material used as piezo electric power harvesting.
4. What is mechanical quality factor?

Unit 8 Electromagnetic Energy Harvesting

Contents

- 8.1 Objective**
- 8.2 Objective**
- 8.3 Linear generators, physics mathematical models, recent applications**
- 8.4 Carbon captured technologies, cell, batteries, power consumption.**
- 8.5 Environmental issues and Renewable sources of energy, sustainability**
- 8.6 Summary**
- 8.7 Questions**

8.1 Objective

To enhance the knowledge of latest design of power harvesting from electromagnetic energy and use it in our daily life.

8.2 Introduction

According to Faraday's law of induction, an electric current is induced when an electric conductor moves through an electric field, or if the magnetic field surrounding the conductor changes. This is called electromagnetic induction and is used by electromagnetic vibration energy harvesters to convert vibrations into electricity. This is the same principle that is used in e.g. transformers and electric motors. Electromagnetic energy harvesting devices are typically designed as a system of springs, magnets and coils, where the magnet and the coil move relative to each other. This movement creates a change in the magnetic flux which produces an electromagnetic force.

Just as piezoelectric energy harvesters, electromagnetic energy harvesters are used as an "perpetual power source" to replace batteries and cables in wireless sensor networks and IoT applications.

Electromagnetic generators have numerous applications from the large-scale generation of power to smaller scale applications in cars to recharge the battery. They can also be used to harvest micro- to milli-Watt levels of power using both rotational and linear devices. Provided a generator is correctly designed and not constrained in size, they can be extremely efficient converters of kinetic energy into electrical. Attempts to miniaturise the technique invariably reduce efficiency levels considerably

8.3 Linear generators, physics mathematical models, recent applications

Linear generators

Linear electric machine with reciprocating mover is of great interest now especially as a linear generator with reciprocating mover which is used together with free-piston engine. High power density in such an electric machine is achieved by the use of permanent magnets and fractional slot concentrated armature winding which together provide a big challenge to designer of such machines. In order to make an initial design, perform optimization procedure and evaluate resulting characteristics several mathematical models of different level of complexity were developed. Sizing equations are based on general equations of balanced electric machine, while main mathematical model takes into account real winding diagram, different length of armature winding and moving inductor and even rectified load. This main model is an analytical one, so it can be used for optimization purposes as it provides very fast calculations. The third model of high discretization level is based on FEM analysis and it allows to obtain generator output characteristics with high accuracy in order to exclude or minimize prototyping stage of design process.

Physics mathematical models

The basic principle on which all electromagnetic generators are based is the Faraday's law of electromagnetic induction. The principle says that the induced emf in a circuit is proportional to the time rate of change of the magnetic flux linked with the circuit.

$$V = -\frac{d\phi}{dt}$$

Here V is the generated voltage or induced emf and ϕ is the flux linkage. In most generator implementations, the circuit consists of a coil of wire of multiple turns and the magnetic field is created by permanent magnets. In such case, the voltage induced in an N turn coil is given by :

$$V = -\frac{d\Phi}{dt} = -N\frac{d\phi}{dt}$$

Here Φ is the total flux linkage of the N turn coil and can be approximated as $N\phi$ and in this case ϕ can be interpreted as the average flux linkage per turn. In most linear vibration generators the magnetic field is produced by a permanent magnet that has no time variation and the motion between the coil and the magnet is linear i.e. in a single direction, say x -direction. Following analysis to this case and

the voltage induced in the coil can then be expressed as the product of a flux linkage gradient and the velocity.

$$V = - \frac{d\Phi}{dx} \frac{dx}{dt} = -N \frac{d\phi}{dx} \frac{dx}{dt}$$

When the coil terminals are connected with a load resistance, the induced current in the circuit will flow in such a direction so as to oppose motion that causes the change in flux linkage. The source of vibration in the environment of the generator will work against this opposing electromagnetic force F_{em} to convert mechanical energy in electrical energy. The mechanical power dissipated in the process may be calculated as

$$P_m = F_{em} \frac{dx}{dt}$$

The amount of power so dissipated will be equal to the electrical power extracted from the generator. If R_L and R_c are load and coil resistances respectively and L_c is the coil inductance then the power dissipation in the coil and load is given by

$$P_{em} = \frac{V}{R_L + R_c + j\omega L_c}$$

Equating P_m and P_{em} we can write

$$F_{em} \frac{dx}{dt} = \frac{V}{R_L + R_c + j\omega L_c}$$

Since F_m is proportional to induced current and hence induced emf, which in turn is proportional to the velocity, we can express F_{em} as the product of an electromagnetic damping D_{em} and the velocity.

$$F_{em} = D_{em} \frac{dx}{dt}$$

From above three equation we can get

$$D_{em} = \frac{1}{R_L + R_c + j\omega L_c} \left(\frac{d\Phi}{dx} \right)^2$$

In order to extract the maximum power in the form of electrical energy, an important goal for the design of a generator is the maximisation of the electromagnetic damping, D_{em} . The maximum damping can be achieved by maximising the flux linkage gradient and minimising the coil impedance. The flux linkage gradient largely depends on

- i) The magnets used to produce the field
- ii) The arrangement of these magnets and
- iii) The area and number of turns for the coil.

The properties of typical magnetic materials will be reviewed in the sections to

come. At the low frequencies generally encountered in ambient vibrations (typically less than 1 kHz), the coil impedance is generally dominated by the resistance. The magnitude of the coil resistance depends on the number of turns and the coil technology. Common technologies for coil fabrication are i) Wire-winding and ii) Micro-fabrication.

8.4 Carbon captured technologies, cell, batteries, power consumption

Carbon Capture

Carbon capture and storage technology captures carbon dioxide (CO₂), then compresses and liquefies it, and finally transports it by pipeline or in tankers to safe and permanent storage in geologic formations. Some of this technology is proven and has been utilized by the oil industry for enhanced oil recovery. However, it has not been adequately demonstrated on large-scale coal-fired power plants as components of integrated clean energy systems. CCS technology for utilization at new, large power plants offers the greatest potential for CCS. CCS can also be used to mitigate CO₂ emissions from other large, stationary source industrial applications.

Carbon Capture : Technology utilized with new large coal plants can reduce emissions by 80% - 85%. However, capture technologies require additional energy, which reduces overall efficiency. Earlier conversion loss estimates of up to 13% have been revised (IEA 2004) down to eight percentage points in existing coal-fired power plants, and to four percentage points in future integrated coal gasification combined cycle (IGCC) designs.

Transportation : The transportation of CO₂ from the source point to the storage site is comparatively inexpensive but substantial infrastructure needs to be built. The mode of transportation (pipeline, tanker, truck, ship) of the CO₂ in gaseous, liquid or supercritical state depends on the pressures and volumes to be shipped, and on the distance to the storage site. A network linking various source points to a storage site would be an asset in regions where storage sites are not proximate to the sources. It remains to be determined how such networks can be sited, financed and operated. At present, 3000 km of dedicated, land-based CO₂ pipelines are in routine operation (IEA 2004).

Storage : Potential underground depositories for CO₂ are plentiful. Global capacities in saline formations are estimated at 1000 to 10000 GtCO₂ and in depleted oil and gas fields at 1100 GtCO₂. This corresponds to 90 - 480 years of current world emissions at 23 - 24 GtCO₂/year. Moreover, CO₂ can also be stored

in abandoned or unminable coal beds or glacial clathrates. At present, more than 33 million tons of CO₂ are being captured and stored in over 70 projects (IEA 2004). Most are experimental, but there are large-scale commercial projects in operation in In Salah (Algeria), Weyburn (Canada), the North Sea (Sleipner), and forthcoming in the Barents Sea, Gorgon (Australia), Gassi Touil (Algeria) and other fields. As noted earlier, CO₂ is injected commercially into oil reservoirs for enhanced oil recovery (EOR) in many parts of the world. Storage-related issues include a reliable assessment of storage capacity; an increased understanding of CO₂ trapping, migration and impact on ground water; and prevention, monitoring and remediation of leaks. Public concern about the risk of leaks needs to be addressed at an early stage by pointing to the present safe storage of millions of tons of CO₂ and the elaboration of designated regulatory regimes. Additionally, issues of short and long-term liability need to be discussed and settled.

8.5 Environmental issues and Renewable sources of energy, sustainability.

The choice of energy systems, like any other feature of major social organisation, is a product of a historical development, of prevailing social value systems and often the role of influential individuals from various layers of society: political decision-makers, industrialists or intellectual figures. As they are not independent of social preferences, one should expect to find different tools available, catering to different positions in the social debate. However, when presented in a systematic fashion, the effects of differences in assumptions become transparent, and the outcome is to exhibit different results as due not just to uncertainty but to specific differences in underlying choices. This would also force the users of these methods to specify their normative positions.

Effect on Environment. However, there are a number of more fundamental social values, associated with basic needs, which are determined by the biology of human beings and thus less subject to modification. Food and (at least in some climates) shelter, an acceptable biological environment (an atmosphere with oxygen, temperatures within certain limits, etc.) and human relations (comprising at least sexual interaction) are in this category. The list may be continued with a number of additional values, which become increasingly linked to the type of society in question. Some such values may be quite basic, but owing to the substantial adaptability of human beings, conditions which violate these values or “needs” may persist without apparent dissatisfaction, at least not on a conscious level. Examples of social values of this type are human interaction in a more broad sense, meaningful activities (“work”) and stimulating physical surroundings.

The present world is to a large extent characterized by a widespread deprivation of even the basic social values: people suffer from hunger, inadequate shelter, bad health, or they are offered unsatisfying work instead of “meaningful activities”, they are surrounded by a polluted environment, ugly varieties of urbanization, etc.

Moving towards energy sustainability will require changes not only in the way energy is supplied, but in the way it is used, and reducing the amount of energy required to deliver various goods or services is essential. Opportunities for improvement on the demand side of the energy equation are as rich and diverse as those on the supply side, and often offer significant economic benefits.

Efficiency slows down energy demand growth so that rising clean energy supplies can make deep cuts in fossil fuel use. A recent historical analysis has demonstrated that the rate of energy efficiency improvements has generally been outpaced by the rate of growth in energy demand, which is due to continuing economic and population growth. As a result, despite energy efficiency gains, total energy use and related carbon emissions have continued to increase. Thus, given the thermodynamic and practical limits of energy efficiency improvements, slowing the growth in energy demand is essential. However, unless clean energy supplies come online rapidly, slowing demand growth will only begin to reduce total emissions; reducing the carbon content of energy sources is also needed. Any serious vision of a sustainable energy economy thus requires commitments to both renewables and efficiency.

8.6 Summary

Electromagnetic power generation is an established technology and the use of this transduction mechanism in small-scale energy harvesting applications is well researched. It is clear from the fundamental principles, and from the analysis of generators tested to date, that electromagnetic devices do not favourably scale down in size. Future applications for micro-scale vibration energy harvesters will be best served by piezoelectric and electrostatic transduction mechanisms that can more easily be realised using MEMS technology. However, where size is not a constraint and conventional discrete coils and magnets can be employed, electromagnetic generators provide the highest levels of performance achievable to date. Electromagnetic energy conversion relies only on relative velocity and change in magnetic flux to generate electricity and therefore an electromagnetic device will not be limited in amplitude by the fatigue strength of, for example, piezoelectric materials. In an electromagnetic generator, the design of the spring element can be chosen purely on the basis of the best spring material and will not be compromised by the inferior spring properties of a piezoelectric material.

The high level of electromagnetic damping achievable also means these devices demonstrate the broadest frequency bandwidth over which energy can be harvested compared with other transduction mechanisms.

8.7 Questions

1. What is electro magnetic energy?
2. What is electromagnetic energy harvesting?
3. What is carbon capture technologies?
4. Mention environmental issues related to carbon capture?

Reference

1. Energy Harvesting Technologies – Shashank Priya, Daniel J. Inman, Springer, 2009.
2. Fundamentals and Applications of Renewable Energy by Mehmet Kanoglu, Yunus A. Cengel, John M. Cimbala, Mc Graw Hill.
3. Renewable Energy Sources and Emerging Technologies, D. P. Kothari, K. C. Singal, Rakesh Ranjan.

